

treadmill h/p/cosmos 150/50 G7  
**original instructions for use**

**IMPORTANT! READ CAREFULLY BEFORE USE! KEEP FOR FUTURE REFERENCE!**



These instructions for use are only valid for the original configuration of the first delivery of the devices pictured below.

Please refer to the latest versions and addendums of this document, available at:

[www.hpcosmos.com/en/contact-support/media-downloads/manuals](http://www.hpcosmos.com/en/contact-support/media-downloads/manuals)





[Click here to download the most recent h/p/cosmos media stick software.](#)



These instructions for use are available on request as print version at [service@hpcosmos.com](mailto:service@hpcosmos.com)





**Product family:** treadmill h/p/cosmos 150/50

**Basic UDI-DI:** 4050588cos31000R4

**Models:**

							
sport						med	
pluto® lt sport		pluto® ef sport		pluto® lt med		pluto® ef med	
UDI-DI: 40505880035794		UDI-DI: 40505880036166		UDI-DI: 40505880035862		UDI-DI: 40505880036234	
[cos31001]		[cos31011]		[cos31002]		[cos31012]	
pluto® lt sport OEM		pluto® ef sport OEM		pluto® lt med OEM		pluto® ef med OEM	
UDI-DI: 40505880035930		UDI-DI: 40505880036302		UDI-DI: 40505880036098		UDI-DI: 40505880036470	
[cos31003]		[cos31013]		[cos31004]		[cos31014]	

			
sport		med	
pluto® sport		pluto® med	
UDI-DI: 40505880036548		UDI-DI: 40505880036616	
[cos31021]		[cos31022]	
pluto® sport OEM		pluto® med OEM	
UDI-DI: 40505880036784		UDI-DI: 40505880036852	
[cos31023]		[cos31024]	

							
sport						med	
stratos® sport		mercury® sport		stratos® med		mercury® med	
UDI-DI: 40505880036920		UDI-DI: 40505880037392		UDI-DI: 40505880037088		UDI-DI: 40505880037460	
[cos31031]		[cos31041]		[cos31032]		[cos31042]	
stratos® sport OEM		mercury® sport OEM		stratos® med OEM		mercury® med OEM	
UDI-DI: 40505880037156		UDI-DI: 40505880037538		UDI-DI: 40505880037224		UDI-DI: 40505880037606	
[cos31033]		[cos31043]		[cos31034]		[cos31044]	

manufacturing year: from 2024 - ...



Franz Harrer  
Company founder  
h/p/cosmos sports & medical gmbh

Dear customer,

Thank you for choosing this premium device.

Since its establishment in 1988, h/p/cosmos® has strongly influenced sports, athletics, ergometry, rehabilitation, and science through the development and distribution of new products, software, system solutions, and application methodologies.

During this time the company, based in Traunstein, Germany, has developed into THE German specialist for manufacturing treadmill ergometers and systems for fitness, sports, sports science, sports medicine, athletics, biomechanics, medicine, rehabilitation, therapy, ergometry, performance diagnostics, and scientific research.

Many developments and pioneering work from h/p/cosmos® have influenced not only product design and functionality but also their usage and methodologies.

Your success with our devices is the primary goal of h/p/cosmos.

This is why we offer individual devices as well as comprehensive system solutions.

You will find a wide range of options and accessories in these instructions for use and at [www.hpcosmos.com](http://www.hpcosmos.com).

At h/p/cosmos, the quality and safety of our products is our highest priority.

These instructions for use include all of the information needed to operate the device correctly and safely.

Please read them carefully before use and keep them available at all times.

We hope you will have a lot of fun and success as you work with your h/p/cosmos device.

A handwritten signature in black ink, appearing to read 'Franz Harrer', with a long horizontal flourish extending to the right.

Franz Harrer  
Company founder  
h/p/cosmos sports & medical gmbh

# Content

<b>1 Symbols and Labels</b> .....	<b>11</b>
1.1 Symbols used (general) .....	11
1.2 Symbols used (transport, packing & storage) .....	12
1.3 Structure.....	12
1.4 Labels and marking on device.....	13
1.4 Labels and marking on device.....	14
<b>2 Description</b> .....	<b>15</b>
2.1 Illustration .....	15
2.2 Function.....	15
<b>3 Intended Use (med)</b> .....	<b>16</b>
3.1 Intended Purpose / Indications / Target Population.....	16
3.2 Intended operator .....	18
3.3 Intended location .....	18
3.4 Intended duration / exercise stop criteria .....	18
3.5 Contraindications.....	19
<b>3 Intended Use (sport)</b> .....	<b>20</b>
3.1 Intended Purpose / Indications.....	20
3.2 Intended operator .....	20
3.3 Intended location .....	20
3.4 Intended duration / exercise stop criteria .....	20
3.5 Contraindications.....	21
<b>4 Safety (med)</b> .....	<b>22</b>
4.1 Safety information – Forbidden use .....	22
<b>4 Safety (sport)</b> .....	<b>24</b>
4.1 Safety information – Forbidden use .....	24
4.2 Fall prevention devices.....	26
4.3 Emergency dismount.....	28
4.4 Emergency stop / Safety stop .....	29
4.5 Quick stop .....	29
4.6 Unauthorized access.....	30
4.7 Residual risk / Side effects .....	30
4.8 Cybersecurity .....	31
4.9 Fire-fighting .....	31
4.10 All-pole disconnection.....	31
4.11 Summary of safety and clinical performance.....	31
See following link:.....	31
<a href="https://www.hpcosmos.com/en/contact-support/media-downloads/certificates">https://www.hpcosmos.com/en/contact-support/media-downloads/certificates</a> .....	31



<b>5 Preparation</b> .....	<b>32</b>
5.1 Preparation of optional adjustable handrails and therapist seats .....	33
<b>6 UserTerminal</b> .....	<b>34</b>
6.1 General Description .....	34
6.2 Standard vs. "It" devices .....	35
<b>7 Position of Subject and Operator</b> .....	<b>36</b>
<b>8 Operation</b> .....	<b>37</b>
8.1 General application procedure .....	37
8.2 Overview of operation modes .....	38
8.3 Manual mode / Quick start .....	40
8.4 Profile mode .....	41
8.5 Cardio mode .....	43
8.6 Test mode .....	45
8.7 Interfere with automatic program .....	47
8.8 Pause function .....	48
8.9 Acceleration levels .....	49
8.10 Options .....	50
User Options .....	50
Owner Options .....	50
<b>9 Accessories / compatible devices</b> .....	<b>51</b>
9.1 Creating Systems .....	51
9.2 Overview of accessories .....	51
9.3 Compatible devices .....	55
<b>10 Disinfection / Cleaning</b> .....	<b>56</b>
<b>11 Maintenance</b> .....	<b>57</b>
11.1 Intervals and competences .....	57
11.2 Daily inspection .....	57
11.3 Lubrication .....	58
11.4 Adjustment of running belt .....	59
11.5 Issues for qualified service personnel .....	60
11.6 Safety inspection .....	60
11.7 Spare parts and consumables .....	60
<b>12 Troubleshooting</b> .....	<b>61</b>
12.1 General troubleshooting .....	61
12.2 Interface troubleshooting .....	62
12.3 Error messages .....	62

<b>13 Technical data (med)</b> .....	<b>63</b>
13.1 UserTerminal .....	63
13.2 Dimensions.....	63
13.3 Loads.....	63
13.4 Emissions .....	63
13.5 Essential performance characteristics.....	63
13.6 Environmental conditions .....	64
13.7 Technical and legal requirements.....	64
13.8 EMC tests.....	65
13.9 Wireless technologies .....	66
13.10 Classification .....	66
13.11 Certificates.....	67
13.12 Interfaces.....	67
13.13 Voltage, Current, Performance.....	67
13.14 Software, Programs.....	68
13.15 All-pole disconnection.....	68
<b>13 Technical data (sport)</b> .....	<b>69</b>
13.1 UserTerminal .....	69
13.2 Dimensions.....	69
13.3 Loads.....	69
13.4 Emissions .....	69
13.5 Essential performance characteristics.....	69
13.6 Environmental conditions .....	70
13.7 Technical and legal requirements.....	70
13.8 EMC tests.....	71
13.9 Wireless technologies .....	72
13.10 Classification .....	72
13.11 Certificates.....	73
13.12 Interfaces.....	73
13.13 Voltage, Current, Performance.....	73
13.14 Software, Programs.....	74
13.15 All-pole disconnection.....	74

14 Liability and Warranty .....	75
15 Expected Lifetime .....	75
16 Disposal.....	76
17 Annex I.....	76
17.1 Installation .....	76
17.2 Commissioning and instruction protocol.....	77
17.3 Commissioning and instruction protocol, signatures .....	78
18.2 Graded test.....	79
18.3 Conconi test .....	79
18.4 Bruce protocol .....	80
18.5 Naughton protocol .....	80
18.6 Balke protocol.....	80
18.7 Cooper protocol.....	81
18.8 Ellestad A protocol.....	81
18.9 Ellestad B protocol .....	81
18.10 Ramp profile .....	82
18.11 Gardner test protocol.....	82
18.12 Fitkids test .....	83







<b>19 Annex III (Accessories)</b> .....	<b>84</b>
Emergency stop retrofitting [cos15933, cos100548, cos15294].....	84
Arm support, optional stop button [cos10107, cos10108].....	85
Elevation 0% to +25% [cos102927].....	86
Special speed 0 to 22 km/h, 150/50 LC [cos103326].....	87
Heart rate measurement POLAR non-coded [cos102818].....	88
Heart rate measurement POLAR H10 [cos101787-01].....	89
Heart rate measurement POLAR OH1 [cos101787_OH1].....	90
Arm support, adjustable [cos12013].....	91
robowalk expander [cos30022, cos30023].....	92
OptoGait, OptoJump [cos102065, cos102054].....	93
optofix [cos103386].....	94
Satellite PC med [cos14970-03].....	95
Safety arch [cos10079-01].....	96
Handrail, adjustable [cos102010], [cos102550], [cos102551].....	97
Handrail, long 1358mm [cos102918].....	98
Handrail, pediatric [cos102400].....	99
Handrail, short (speed) left / right [cos14763-01, cos102803].....	100
Handrail very short [cos103322].....	101
Foot rails wide [cos103928].....	102
Reverse treadmill belt rotation [cos103330], [cos00098100045-02], [cos10181-03].....	103
Crossbar front rail [cos102426].....	104
Safety arch retrofit / replacement kit h=220cm.....	105
(cos14424-01; cos14424-01ret; cos14425-01; cos14425-01ret).....	105
Floor protection mat [cos103852].....	106
Wheelchair ramp [cos16186-02], [cos102931], [cos14664-03].....	107
<b>20 Contact</b> .....	<b>108</b>

# 1 Symbols and Labels



## 1.1 Symbols used (general)

Illustration	Description	Reference
	CE sign, declaration that the essential requirements (here with number of notified body) were met	(acc. to medical device directive 93/42/EEC or medical device regulation EU 2017/745)
	CE sign, declaration that the essential requirements were met	(acc. to machinery directive 2006/42/EC)
	General warning (danger, warning or caution statements)	(DIN EN ISO 7010 W001)
	Warning of obstacles (stumbling)	(DIN EN ISO 7010 W007)
	Warning of electrical voltage	(DIN EN ISO 7010 W012)
	Warning of hot surface	(DIN EN ISO 7010 W017)
	Warning of counter rotating rollers (trapping zones)	(DIN EN ISO 7010 W025)
	Follow instructions for use	(DIN EN ISO 7010 M002)
	Potential equalization	(IEC 60445)
	Protection ground	(IEC 60417-5019)
	Chassis ground	(IEC 60417-5020)
	Alternating current (AC)	(IEC 60417-5032)
	Applied part of type B	(IEC 60417-5840)
	Manufacturer	(ISO 15223-1)
	Manufacturing date	(ISO 15223-1)
	Separate collection for electrical and electronic equipment	(2012/19/EU)
	Medical Device sign	(acc. medical device regulation EU 2017/745)
	Unique Device Identifier / Production Identifier (incl. manufacturer ID, device ID, manufacturing date and serial number)	(acc. medical device regulation EU 2017/745)

## 1.2 Symbols used (transport, packing & storage)

Illustration	Description	Reference
	Fragile, Handle with care	(ISO7000-0621)
	This way up	(ISO7000-0623)
	Keep dry	(ISO7000-0626)
	Centre of gravity	(ISO7000-0627)
	Temperature limitations	(ISO7000-0632)
	Do not stack	(ISO7000-2402)

## 1.3 Structure

Illustration	Description
	Pages marked with the following symbol are applicable for medical devices, only.
	Pages marked with the following symbol are applicable for sports devices, only.

All pages without special marking (med or sport) are applicable for both applications and devices.

## 1.4 Labels and marking on device



In case of any visible or assumed wear and tear (of the device, accessories, labels, etc.), unplug device, exclude reconnection, mark clearly and inform h/p/cosmos service personnel via telephone and writing. Do not change or remove any labels!

Illustration	Description	Order number
	name plate	-
	UDI name plate with serial number, manufacturer and manufacturing date	-
	label "caution danger zones"	cos10508-03
	label "caution danger zones"	cos10508-04
	label "before opening disconnect mains"	cos11880
	label "follow instructions"	cos101380
	label "potential equalization"	cos101594
	label "next inspection 20xx" + base label	cos14543-20xx + cos11787
	label "adjust running belt"	cos10512
	label "adjust running belt"	cos10512-01
	label "lubrication"	cos10510
<p><b>Safety advice according to DIN EN ISO20957</b>          WARNING! Heart rate monitoring systems may be inaccurate.          Incorrect or over exercising may result in serious injury or death.          If you feel faint or dizzy stop exercising immediately and consult a medical doctor.</p>	label "safety advice acc. to EN ISO 20957-1"	cos103963
	label "h/p/cosmos address"	cos10144-01



## 1.4 Labels and marking on device

In case of any visible or assumed wear and tear (of the device, accessories, labels, etc.), unplug device, exclude reconnection, mark clearly and inform h/p/cosmos service personnel via telephone and writing. Do not change or remove any labels!

Illustration	Description	Order number
	label "NFC sensor"	-
	marking on running belt	-

## 2 Description

### 2.1 Illustration

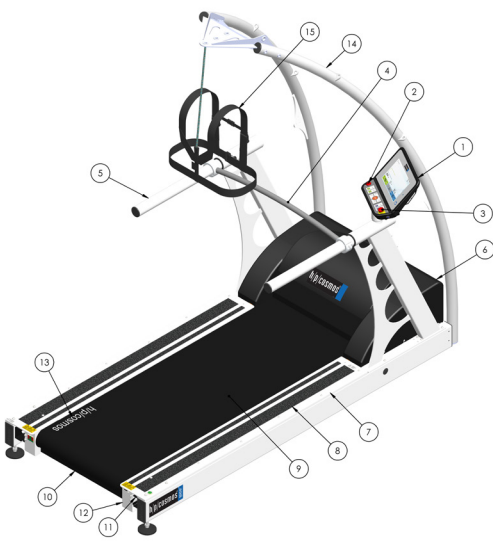
No.	Description	Illustration
1.	UserTerminal	
2.	Pull cord safety stop (ripcord / safety lanyard)	
3.	Emergency stop	
4.	Crossbar-frontrail	
5.	Side handrail	
6.	Motor cover	
7.	Foot rail	
8.	Non slip surface	
9.	Running deck	
10.	Running belt	
11.	Rear roller	
12.	Rear roller protective cover	
13.	Marking of running belt	
14.	Safety arch	
15.	Safety harness / Chest belt	

### 2.2 Function

The treadmill has two essential performance characteristics: Speed and elevation.

The rotation of the running belt represents the speed.

The raising of the whole treadmill frame incl. running deck enables the elevation.

Both parameters are manually adjustable on the UserTerminal.

Furthermore, operation is possible via pre- and self-defined modes.

Operation is also possible via external devices (PC, ECG, etc.).

The chapter "operation" gives a detailed description of all functions.

The chapter "technical data" shows technical details.

The treadmill is driven by powerful motors.

For that reason it is very important to follow the safety information, in order to avoid injury or death.

As previously described, the treadmill contains a number of standardized protocols.

Nevertheless, the treadmill does not provide recommendations for treatment.

The decision regarding the correct load is the responsibility of the medical doctor.

Depending on the application, the load includes speed, elevation, distance, heart rate, body weight or motion support, etc..

## 3 Intended Use (med)

### 3.1 Intended Purpose / Indications / Target Population

h/p/cosmos medical treadmills are intended for walking or running\* in place for

- Recreational fitness training (incl. athletes)
- Gait training (with or without body weight support)

h/p/cosmos medical treadmills can be used in combination with external devices for walking or running\* in place as

- Stressing devices for neuromuscular and biomechanical measurements (e.g. EEG, EMG, motion analysis)
- Stressing devices for cardiovascular measurements (e.g. ECG)
- Stressing devices for cardiopulmonary measurements (e.g. ergospirometry)

\* Devices marked with an "r" or "rs" like "h/p/cosmos saturn 250/75 r" are intended for applications with wheels as well.

Applications with wheels include cycling, roller skiing, wheelchair applications, etc...

Caution: In which ever mode, function, program, test or feature, the treadmill does not provide any kind of medical treatment proposal nor medical assessment with analysis. The treadmill is purely used as a stressing device and training equipment.

Prescribed fall prevention device for any application where falling might cause an unacceptable risk such as

- while performing sprints, high speed training or max. endurance tests
- while training on running surfaces wider than 65 cm
- for children (<14 years)
- for subjects with all kind of disabilities, impairments (visual, hearing, balance, etc.), activity limitations and participation restrictions
- for subjects with recent hip replacement, intracorporal probes, osteoporosis, etc.
- during reverse belt rotation at speeds higher than 5 km/h.
- It is not allowed to run with the back to the crossbar or to the UserTerminal to prevent from collision.
- during all use with wheels (cycling, wheelchair, inline-skating or roller-ski) for the "r" models

#### Intended patient population:

Adults and children > 1 year.

The subject of a medical application is not necessarily a patient. Therefore, the IFUs use the term "subject" for patients as well as for athletes under test.

h/p/cosmos medical treadmills may be operated with healthy subjects as well.

For applications with healthy subjects, please apply the instructions for use for sports devices, available at [www.hpcosmos.com](http://www.hpcosmos.com)

It is impossible to list all indications, target population (age, gender, weight range, height range) and target user groups for treadmill training and treadmill testing, since the indications, target population and target user groups most likely correspond to recommendations for walking and/or running overground.

The treadmill does not provide recommendations for treatment and target population.

It is important to notice that the decision to use the devices with their potential risks and complications for diagnosis, rehabilitation or therapy of a particular patient is the essential responsibility of the medical operator.

The clinical user's judgment, on the other hand, must be based on current knowledge in medical science and the specific situation of the patient.

The indications, target population and target user groups for treadmill testing and treatment have to be decided by the medical doctor and primarily have to be derived from international accepted guidelines.

**Examples:**

2020 ESC Guidelines on Sports Cardiology and Exercise in Patients with Cardiovascular Disease

ESC European Society of Cardiology Clinical Practice Guidelines

<https://academic.oup.com/eurheartj/article/42/1/17/5898937>

ACC/AHA Guidelines for Exercise Testing.

A Report of the American College of Cardiology/American Heart Association

Task Force on Practice Guidelines (Committee on Exercise Testing)

<https://www.jacc.org/doi/pdf/10.1016/s0735-1097%2897%2900150-2>

American Academy of Family Physicians Foundation

Exercise Stress Testing: Indications and Common Questions

<https://www.aafp.org/afp/2017/0901/p293.html>

Physical Therapy and Rehabilitation Journal

Robotic-Assisted, Body-Weight–Supported Treadmill Training (BWSTT) in Individuals Following Motor Incomplete Spinal Cord Injury

<https://academic.oup.com/ptj/article/85/1/52/2805006>

The NEW ENGLAND JOURNAL of MEDICINE

Body-Weight–Supported Treadmill Rehabilitation after Stroke

<https://www.ctsi.ucla.edu/education/files/view/training/docs/dobkin-NEJM-BWSTT-after-stroke.pdf>

### 3.2 Intended operator

- Medical staff only
- that has been carefully trained according to these instructions for use
- that is working according to the prescription of the medical doctor, where applicable and necessary
- the subject is not the intended operator.

But the intended operator is authorized to allow the subject to control the device according to the instructions and under the permanent observation of the intended operator. This means the operation of the device remains the responsibility of the intended operator at all times, taking the physical and mental condition of the subject into account.

The intended operator has to be within permanently reach (patient area = 1.5m radius).

### 3.3 Intended location

- Medical facilities only
- no use at home or in home healthcare environments (acc. to IEC 60601-1-11), (EMC tested with home healthcare limits)
- no outdoor use
- no direct sunlight
- Sufficiently lighted for proper readability of warning, labels, displays and operation elements
- Proper environmental conditions (see "Technical Data")
- Stationary training equipment: Not intended to be moved after installation by professional staff.

### 3.4 Intended duration / exercise stop criteria

- Depending on the prescription of the medical doctor
- WARNING! Heart rate monitoring systems may be inaccurate.
- Incorrect or over exercising may result in serious injury or death.
- If you feel faint or dizzy stop exercising immediately and consult a medical doctor.
- Further exercise test stop criteria see guidelines for various treadmill exercise and treadmill tests.

Duration of use: can be following both, depending on the doctor's prescription:

Transient: Normally intended for continuous use for less than 60 minutes

Short term: Normally intended for continuous use for between 60 min. and 30 days

## 3.5 Contraindications

### Absolute contraindications

(have to be excluded before the treadmill is used)

- Acute myocardial infarction (within 2 days)
- Instable angina pectoris
- Cardiac arrhythmia pathology and/or limited hemodynamics
- Symptomatic massive aortic stenosis
- Uncompensated / uncontrolled heart insufficiency
- Acute pulmonary embolism or pulmonary infarction
- Acute endocarditis, myocarditis, pericarditis
- Acute aortic dissection
- Acute coronary syndrome
- Acute phlebothrombosis of the lower extremities
- Febrile infections
- Pregnancy
- Acute thrombosis
- Fresh wounds e.g. after surgery
- Acute fracture
- Damaged disc or traumatic disease of the spine
- Epilepsy
- Inflammations
- Acute migraine
- uncontrolled heart failure
- dissecting aneurysm
- recent aortic surgery and ECG abnormalities, such as abnormal ST-segment response (horizontal, planar or downsloping depression of >1 mm, T-wave elevation of > 1 mm in leads without Q-waves, and Twavechanges such as inversion and pseudo-normalization when an inverted T-wave becomes upright.

### Relative contraindications

(The application may be started if the possible benefits exceed the risks.

The decision has to be made by the medical doctor before the treadmill is used)

- Left main coronary stenosis
- Main artery disease
- Cardiac valve disease of moderate severity
- Known electrolyte imbalance
- Arterial hypertension (RR > 200 mm Hg syst. > 110 mm Hg diast.)
- Tachyarrhythmia or bradyarrhythmia
- Hypertrophic cardiomyopathy and other forms of outflow tract obstruction
- Higher degree atrioventricular AV-blocking
- Anemia
- Physical and/or mental disabilities leading to inability to exercise adequately
- Partially invasive medical devices (probes, infusions, catheters, external fixators, etc.)
- Cardiac pacemaker
- Visual impairment (vision < 30% acc. to WHO)

Further contraindications may occur. This has to be evaluated by the medical doctor.

In case of relative contraindications permanent observation of the subject by medical staff is obligatory.

## 3 Intended Use (sport)

### 3.1 Intended Purpose / Indications

h/p/cosmos sports treadmills are intended for walking or running\* in place.

Do not use h/p/cosmos sports treadmills for medical applications.

\* Devices marked with an "r" or "rs" like "h/p/cosmos saturn 250/75 r" are intended for applications with wheels as well.

Applications with wheels include cycling, roller skiing, wheelchair applications, etc...

Caution: In which ever mode, function, program, test or feature, the treadmill does not provide any kind of medical treatment proposal nor medical assessment with analysis. The treadmill is purely used as a stressing device and training equipment.

Prescribed fall prevention device for any application where falling might cause an unacceptable risk such as

- while performing sprints, high speed training or max. endurance tests
- while training on running surfaces wider than 65 cm
- for children (<14 years)
- for subjects with all kind of disabilities, impairments (visual, hearing, balance, etc.), activity limitations and participation restrictions
- for subjects with recent hip replacement, intracorporal probes, osteoporosis, etc.
- during reverse belt rotation at speeds higher than 5 km/h.
- during all use with wheels (cycling, wheelchair, inline-skating or roller-ski) for the "r" models

### 3.2 Intended operator

- Adult persons carefully trained according to these instructions for use.
- A professional supervisor has to be in the same room.

### 3.3 Intended location

- No use at home or in home healthcare environments (acc. to IEC 60601-1-11), (EMC tested with home healthcare limits)
- No outdoor use
- No direct sunlight
- Sufficiently lighted for proper readability of warning, labels, displays and operation elements
- Proper environmental conditions (see "Technical Data")
- Stationary training equipment: Not intended to be moved after installation by professional staff.

### 3.4 Intended duration / exercise stop criteria

- Depending on the condition of the subject
- Exclude overloading or overstraining of the subject.
- WARNING! Heart rate monitoring systems may be inaccurate.
- Incorrect or over exercising may result in serious injury or death.
- If you feel faint or dizzy stop exercising immediately and consult a medical doctor.
- Further exercise test stop criteria see guidelines for various treadmill exercise and treadmill tests.



### 3.5 Contraindications

(have to be excluded before the treadmill is used)

- Acute myocardial infarction (within 2 days)
- Instable angina pectoris
- Cardiac arrhythmia pathology and/or limited hemodynamics
- Symptomatic massive aortic stenosis
- Uncompensated / uncontrolled heart insufficiency
- Acute pulmonary embolism or pulmonary infarction
- Acute endocarditis, myocarditis, pericarditis
- Acute aortic dissection
- Acute coronary syndrome
- Acute phlebothrombosis of the lower extremities
- Febrile infections
- Pregnancy
- Acute thrombosis
- Fresh wounds e.g. after surgery
- Acute fracture
- Damaged disc or traumatic disease of the spine
- Epilepsy
- Inflammations
- Acute migraine
- Left main coronary stenosis
- Main artery disease
- Cardiac valve disease of moderate severity
- Known electrolyte imbalance
- Arterial hypertension (RR > 200 mm Hg syst. > 110 mm Hg diast.)
- Tachyarrhythmia or bradyarrhythmia
- Hypertrophic cardiomyopathy and other forms of outflow tract obstruction
- Higher degree atrioventricular AV-blocking
- Anemia
- Physical and/or mental disabilities leading to inability to exercise adequately
- Partially invasive medical devices (probes, infusions, catheters, external fixators, etc.)
- Cardiac pacemaker
- Visual impairment (vision < 30% acc. to WHO)

Sources:

<http://leitlinien.dgk.org> (German Cardiac Society)  
[www.acc.org](http://www.acc.org) (American College of Cardiology Foundation)

## 4 Safety (med)

h/p/cosmos medical treadmills may be operated with healthy subjects as well.

The safety notes, warnings and precautions have to be pointed out to every user and operator and displayed within sight of the running machine.

Please refer to the latest versions on our website:

- safety notes, warnings and FSCA Field Safety Corrective Actions: <https://www.hpcosmos.com/en/safety>
- media stick software and manuals: <https://www.hpcosmos.com/en/contact-support/media-downloads/manuals>
- installation, commissioning and instruction protocol: <https://www.hpcosmos.com/en/contact-support/media-downloads/manuals>

Any serious incident in relation to the device has to be reported to the manufacturer and the competent authority of the EU Member State in which the user and/or patient is established as well as to EUDAMED database based on MDR.

### 4.1 Safety information – Forbidden use

Obey the following danger, warning and caution statements strictly in order to prevent serious injury or death!

- Prescribed fall prevention for any application where falling might cause an unacceptable risk (high speed or special applications, applications with subjects not able to jump off the running belt such as children, physically impaired, etc.)
- The automatic modes must only be performed on the prescription of the medical doctor.
- During stress tests a medical doctor has to be available at any time.
- Do not use the device with children <12 months.
- Exclude access of unsupervised children (< 14 years) onto or near any parts of the device (incl. accessories, packaging, lubrication and service material).
- In case of application with children (> 1, < 14 years) permanent observation of the subject by medical staff is obligatory.
- Animals must not be in the same room with the device.
- Only carefully trained medical staff is allowed to use the device.
- Do not use the safety harness on bare skin.
- WARNING! Heart rate monitoring systems may be inaccurate.
- Incorrect or over exercising may result in serious injury or death.
- If you feel faint or dizzy stop exercising immediately and consult a medical doctor.
- Further exercise test stop criteria see guidelines for various treadmill exercise and treadmill tests.
- Exclude overloading or overstressing of the subject.
- The subject has to be checked by a medical doctor before using the device.
- A defibrillator must be present at any time.
- The intended operator has to be in reach of at least one emergency stop/off at any time.
- Obey all information given in these instructions for use.
- Do not use the device against the intended use.
- Do not use the device in case one or more of the listed contraindications prevail.
- In case of relative contraindications permanent observation of the subject by medical staff is obligatory.
- Neither subject nor operator must be under the influence of alcohol, drugs or anesthetics.
- Start the use of the treadmill with slow walking, especially for beginners.
- Make sure the space under the treadmill is free from persons, body parts or objects, especially when switching on (treadmill will lower during initialization) and when changing the elevation.
- Do not enter the device when running belt is rotating.
- Do not step on rear roller.
- Do not stand on or enter the running deck when device is in elevation (running belt might slip through due to gravity).

- Make sure no objects, sand, stones, liquids, towels, jewellery, cell phones, containers with liquid etc. can fall into the device or onto the running surface or underneath the running belt.
- Do not use the device with wheels (bikes, wheelchairs, inline skates, etc.). \*
- Do not enter the device without athletic or other appropriate shoes. Do not use high heels, spikes, studs, sandals, etc. \*\*
- Do not turn around, walk sideways or backwards; do not jump on or off the running belt while it is in motion.
- Do not touch the running belt while it is in motion (besides contact with feet).
- Do not lean on the UserTerminal - do not apply pressure to the displays - press keys softly.
- Ensure assist mean, accessories, cables etc. do not extend into the running area.
- Do not insert any object (especially no metal objects such as a pin or a wire) into any gap or any outlet on the device.
- Do not touch the subject and external electrical devices at the same time.
- Always the latest command will be executed, regardless of whether it came via interface or from the UserTerminal during one of the four modes. Only stop command has higher priority and cannot be overwritten.
- Be aware that electromagnetic interferences may cause a fail-safe mode, the running belt will stop with a pre-defined deceleration ramp.
- **WARNING:** To avoid the risk of electric shock, this equipment must only be connected to a supply mains with protective earth.
- **WARNING:** Do not use portable high frequency communication devices in the subject environment (see "position of subject and user"). Disregard can cause loss of performance.
- Free standing equipment has to be installed on a stable and levelled base.
- Choose proper floor, shoes, clothing and humidity, in order to prevent electrostatic charge and discharge (also see technical data).
- Do not use the device without instruction by authorized personnel acc. to the instruction protocol.
- Regard safety area behind device of 2.0 m x width of treadmill.
- Operator and subject have to be aware of automatic load changes during profile, cardio and test mode.
- Unmeant trapping hazards: Take off ties, scarfs or other clothes that may be trapped. Secure long hair and ribbons during maintenance and training in order to prevent being captured in trapping zones.
- Perform a daily visual inspection (see chapter "maintenance").
- Obey the maintenance intervals claimed in chapter "maintenance".
- Obey the competences claimed in chapter "maintenance".
- A second person has to be present during maintenance.
- In case of any visible or assumed defects or malfunctions (of the device, accessories, software, etc.), unplug device, exclude reconnection, mark clearly and inform h/p/cosmos service personnel via telephone and writing.
- In case of any visible or assumed wear and tear (of the device, accessories, labels, etc.), unplug device, exclude reconnection, mark clearly and inform h/p/cosmos service personnel via telephone and writing. Do not change or remove any labels!
- In case of any fluid entering into the device, unplug device, exclude reconnection, mark clearly and inform h/p/cosmos service personnel via telephone and writing.
- Do not modify the device, configurations, accessories or software in any way.
- Do not connect any devices, accessories or software, not listed in "accessories / compatible devices".
- Disinfect the device before and after every treatment.
- Disconnect the device and all accessories from mains power supply before cleaning or disinfection.
- Do not save personal data (names, address, etc.) or patient data (indications, etc.) on the UserTerminal, for example in file names or profile names.
- **Warning:** Portable RF communications equipment (incl. peripherals such as antenna cables and external antennas) should be used no closer than 30 cm to any part of the device, incl. cables specified by the manufacturer. Otherwise degradation of the performance of this equipment could result.
- There must be no electrical devices within the patient environment (device + 1.5m) which are not part of an ME-system. (See chapter "position of subject and user.")

\* Devices marked with an "r" or "rs" like "h/p/cosmos saturn 250/75 r" are intended for applications with wheels as well. Applications with wheels include cycling, roller skiing, wheelchair applications, etc.

\*\* Devices supplied with the special "running belt for ski and spike applications" (see "Annex III (Accessories)") are intended for application with spikes or studs as well.

## 4 Safety (sport)

h/p/cosmos sports treadmills are intended for walking or running\* in place.

Do not use h/p/cosmos sports treadmills for medical applications.

The safety notes, warnings and precautions have to be pointed out to every user and operator and displayed within sight of the running machine.

Additional and latest safety notes and warnings see: <https://www.hpcosmos.com/en/safety>

Any serious incident in relation to the device has to be reported to the manufacturer and the competent authority of the EU Member State in which the user and/or subject is established.

### 4.1 Safety information – Forbidden use

Obey the following danger, warning and caution statements strictly in order to prevent serious injury or death!

- Prescribed fall prevention for any application where falling might cause an unacceptable risk (high speed or special applications, applications with subjects not able to jump off the running belt such as children, physically impaired, etc.)
- Only carefully trained staff is allowed to use the device.
- Do not use the device with children <14 years.
- Exclude access of unsupervised children (< 14 years) onto or near any parts of the device (incl. accessories, packaging, lubrication and service material).
- Do not use the safety harness on bare skin.
- WARNING! Heart rate monitoring systems may be inaccurate.
- Incorrect or over exercising may result in serious injury or death.
- If you feel faint or dizzy stop exercising immediately and consult a medical doctor.
- Further exercise test stop criteria see guidelines for various treadmill exercise and treadmill tests.
- Exclude overloading or overstressing of the subject.
- The subject has to be checked by a medical doctor before using the device.
- A defibrillator must be present at any time.
- The intended operator has to be in reach of at least one emergency stop/off at any time.
- Obey all information given in these instructions for use.
- Do not use the device against the intended use.
- Do not use the device in case one or more of the listed contraindications prevail.
- Neither subject nor operator must be under the influence of alcohol, drugs or anesthetics.
- Start the use of the treadmill with slow walking, especially for beginners.
- Make sure the space under the treadmill is free from persons, body parts or objects, especially when switching on (treadmill will lower during initialization) and when changing the elevation.
- Do not enter the device when running belt is rotating.
- Do not step on rear roller.
- Do not stand on or enter the running deck when device is in elevation (running belt might slip through due to gravity).
- Make sure no objects, sand, stones, liquids, towels, jewellery, cell phones, containers with liquid etc. can fall into the device or onto the running surface or underneath the running belt
- Do not enter the device without athletic or other appropriate shoes. Do not use high heels, spikes, studs, sandals, etc. \*\*
- Do not use the device with wheels (bikes, wheelchairs, inline skates, etc.).
- Do not turn around, walk sideways or backwards; do not jump on or off the running belt while it is in motion.
- Do not touch the running belt while it is in motion (besides contact with feet).
- Do not lean on the UserTerminal - do not apply pressure to the displays - press keys softly.
- Ensure assist mean, accessories, cables etc. do not extend into the running area.

- Do not insert any object (especially no metal objects such as a pin or a wire) into any gap or any outlet on the device.
- Do not touch the subject and external electrical devices at the same time.
- Always the latest command will be executed, regardless of whether it came via interface or from the UserTerminal during one of the four modes. Only stop command has higher priority and cannot be overwritten.
- Be aware that electromagnetic interferences may cause a fail-safe mode, the running belt will stop with a pre-defined deceleration ramp.
- **WARNING:** To avoid the risk of electric shock, this equipment must only be connected to a supply mains with protective earth.
- **WARNING:** Do not use portable high frequency communication devices in the subject environment (see “position of subject and user”). Disregard can cause loss of performance.
- Free standing equipment has to be installed on a stable and levelled base.
- Choose proper floor, shoes, clothing and humidity, in order to prevent electrostatic charge and discharge (also see technical data).
- Do not use the device without instruction by authorized personnel acc. to the instruction protocol.
- Regard safety area behind device of 2.0 m x width of treadmill.
- Animals must not be in the same room with the device.
- Operator and subject have to be aware of automatic load changes during profile, cardio and test mode.
- Unmeant trapping hazards: Take off ties, scarfs or other clothes that may be trapped. Secure long hair and ribbons during maintenance and training in order to prevent being captured in trapping zones.
- Perform a daily visual inspection (see chapter “maintenance”).
- Obey the maintenance intervals claimed in chapter “maintenance”.
- Obey the competences claimed in chapter “maintenance”.
- A second person has to be present during maintenance.
- In case of any visible or assumed defects or malfunctions (of the device, accessories, software, etc.), unplug device, exclude reconnection, mark clearly and inform h/p/cosmos service personnel via telephone and writing.
- In case of any visible or assumed wear and tear (of the device, accessories, labels, etc.), unplug device, exclude reconnection, mark clearly and inform h/p/cosmos service personnel via telephone and writing. Do not change or remove any labels!
- In case of any fluid entering into the device, unplug device, exclude reconnection, mark clearly and inform h/p/cosmos service personnel via telephone and writing.
- Do not modify the device, configurations, accessories or software in any way.
- Do not connect any devices, accessories or software, not listed in “accessories / compatible devices”.
- Disinfect the device before and after every treatment.
- Disconnect the device and all accessories from mains power supply before cleaning or disinfection.
- Do not save personal data (names, address, etc.) or patient data (indications, etc.) on the UserTerminal, for example in file names or profile names.
- **Warning:** Portable RF communications equipment (incl. peripherals such as antenna cables and external antennas) should be used no closer than 30 cm to any part of the device, incl. cables specified by the manufacturer. Otherwise degradation of the performance of this equipment could result.

## 4.2 Fall prevention devices

A fall prevention device is the only effective way to protect the subject from falling.

Prescribed fall prevention for any application where falling might cause an unacceptable risk (details see chapter 4.1).

h/p/cosmos provides fall prevention devices in the form of a safety arch or a body weight support device (airwalk).

It is up to the operator to use any other certified device that prevents the subject from falling and complies with IEC 60601-1 and EN 957-6 in combination with this treadmill.

The pull-cord safety stop is not a fall prevention.

Do not use the safety harness on bare skin.

Treadmill with safety arch



Body weight support device airwalk®

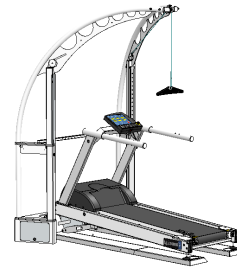

Further information see "Annex III (accessories)"

### Description

### Illustration

Put on the safety harness so that the h/p/cosmos logo is facing outside.

The h/p/cosmos logo has to be visible in the back as well.



Close buckles.



Tighten shoulder and chest straps.



Use carabiner to connect safety harness with rope and adjust the rope length in order to prevent falling onto the running belt.



select max. patient weight / triggering of STOP function

- 1.) rope not through upmost eyelet -> max. 250 kg / trigger at 15 kg
- 2.) rope through upmost eyelet -> max. 300 kg / trigger at 30 kg



Description	Illustration
-------------	--------------

Press lever to release rope.

Check rope, harness / chest belt and switch function daily.

Renew the rope and harness every 24 months, or sooner if it shows any signs of wear or damage.

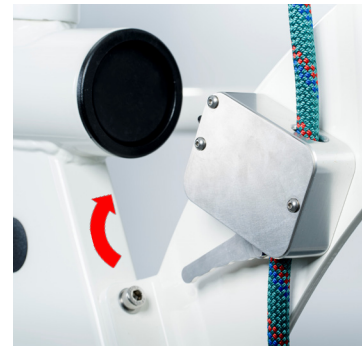

Select the optimum user position (especially during downhill and / or reverse) on the treadmill using the safety arch.



In order to re-open the buckle, press the fastener with thumb and index finger.

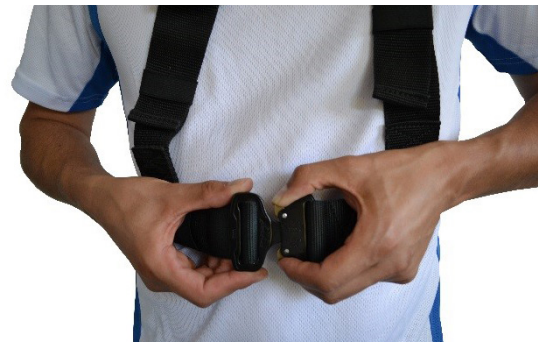



## 4.3 Emergency dismount

Subject is conscious and aware of danger.

- Subject grabs the handrails
- Subject jumps off the running belt onto the foot rails
- Operator / subject hits the emergency stop

Subject is conscious but not aware of danger.

- Subject stumbles and falls into fall prevention device.
- Treadmill stops
- Operator / subject hits the emergency stop
- Operator helps subject stand up again.
- Operator helps subject exit the device.

Subject lost consciousness and is hanging in the fall prevention device.



- Hit the emergency stop.
- Call a medical doctor.
- Call one or more persons, strong enough to carry the subject.
- Inform the third person that you will open the buckle of the safety harness
- Open the buckle of the safety harness.
- Subject will slide into the other person's arms.
- Render first aid.

## 4.4 Emergency stop / Safety stop

Do only use in case of emergency.

Do not use as normal stop button.

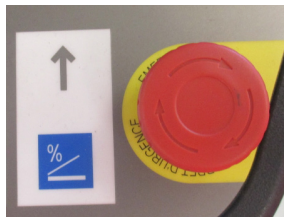
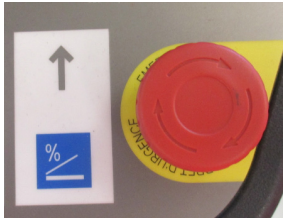
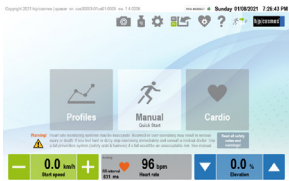
Do not stand on or enter the running deck when device is in elevation (running belt might slip through due to gravity).

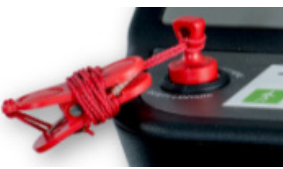
	Operation	Result	Release	Restart
UserTerminal		Power supply to motion generating components interrupted  Running belt spins out (until 0 km/h) with undefined deceleration Movement of elevation system stops		
	Push button		turn and pull button	
Pull cord safety stop		UserTerminal still on and displays:  Interface communication not interrupted		Restart application.
	Pull cord with magnet from metal plate		Reconnect magnet with cord to metal plate	

The operator has to be in reach of the emergency off at any time.



If the operator is not able to reach the emergency stop button at the UserTerminal (locomotion therapy, body height, obstacles, etc.), the operator must install an additional emergency stop within reach (see accessories).

## 4.5 Quick stop

Do only use in case of emergency.

Do not use as normal stop button.

Do not stand on or enter the running deck when device is in elevation (running belt might slip through due to gravity).

	Operation	Result	Release	Restart
Safety arch		Running belt stops with predefined deceleration Movement of elevation system stops  UserTerminal displays "pull stop" 		
	Pulling force on rope	Mains connection and interface communication not interrupted	Release pulling force	

## 4.6 Unauthorized access

See Options 200 - 204 to lock the whole device or individual modes.

Access to options see Chapter 8.10 "User Options".

## 4.7 Residual risk / Side effects

After risk reduction all risks are "acceptable".

In case fall prevention device (safety arch with harness and chest belt or airwalk unweighting device) is not applied or not applied correctly, there are residual risks, such as falling of a person resulting in skin abrasions, bruises, fractures or in worst case even death.

These risks may occur during use as well as when entering or leaving the device and during stand-still in elevation.

Furthermore there is residual risk such as unintended overload of the subject caused by wrong operation, wrong assessment, or wrong application of the operator and also incorrect data transfer (e.g. electromagnetic interferences, software failure, etc.). Even the best software and hardware safety concepts can never completely rule out a failure of software or hardware and thereby a theoretically possible overloading of the subject.

Since the treadmill is an electrically operated device, an electric shock, which might result in death can never be ruled out, although the design and verification is according to the relevant standards for electrical safety of medical devices, an electric shock, which can result in death, can never be ruled out completely.

Due to their advanced technology the PC and the touch panel have an expected lifetime of 5 years. The thoroughly carried out risk management evaluates the risk emerging from a PC breakdown as acceptable.

The residual risk of strangulation and trapping of clothes / shoes / fingers / hair or other body parts in the elevation system, belt re-entry zones or other moving parts can not be excluded as well. These risks are reduced by safety information within the IFU.

It cannot be excluded that unintended or forbidden use might cause further not yet regarded risks and that already regarded risks might have been estimated incorrectly. It can also not be excluded that the daily use of the medical product might show further risks.

For medical applications such as ergometry, diagnostics and therapy there are alternatives to treadmill application such as bicycle ergometry (without natural gait movement) or overground gait therapy (secured only by the therapist), etc.

The benefits of treadmill training in contrast to these alternatives are clearly outweighing the residual risks of falling or overload with the known consequences.

In this risk analysis the "present state" of the device has been evaluated.

Having carried out the evaluation and validation of the product, the risk of appearance of a not acceptable risk is very low.

The device (it's construction, it's function as well as the intended application) does - under normal conditions - not represent any unjustifiable risk for the subject, the user, the operator or third persons.

However, the risk of injury or even death due to a malfunction of the treadmill is very low.

In over 35 years of history (since 1988) and with more than 12,000 h/p/cosmos treadmills on the worldwide market, there has never been such a reported incident.

Thus, the h/p/cosmos products covered under this risk management file are considered to be very safe, in compliance with applicable standards and regulatory requirements and can be released for serial production to be placed on the market.

## 4.8 Cybersecurity

Limitation of unauthorized access through

- deactivation of
- boot option from external devices
- automatic Windows updates
- password protection of
- whole device
- Windows access
- BIOS access
- possible exclusion / no essential need for
- internet
- WIFI
- bluetooth

Limitation of data loss through

- internal energy storage
- backup option (USB) for training data

Further measures

- software design acc. to IEC 62304 (software life-cycle processes)
- re-confirmation of external control on the UserTerminal
- warnings concerning handling of patient data in instructions for use
- information / warnings for intergration by IT administrators in instructions for use
- no patient database

## 4.9 Fire-fighting

Apply all-pole disconnection from voltage power supply, preferably through triggering respective FUSE circuit breaker.

Do not use liquid fire-fighting resources.

Use preferably CO2 or powder fire extinguisher.

## 4.10 All-pole disconnection

The following options are available for all-pole disconnection from voltage power supply:

- Unplug device from power socket.
- Unplug cable from device (if possible).
- Switch off device protection switch.
- Trigger residual current circuit breaker / RCD of the building.

Maintain enough free space to ensure access to cables, power plugs and the circuit breaker (see “position of subject and operator”).

## 4.11 Summary of safety and clinical performance

See following link:

<https://www.hpcosmos.com/en/contact-support/media-downloads/certificates>

## 5 Preparation

### Description

Perform daily inspection as described in “daily inspection”.

### Illustration



Explain device and application to subject.  
Explain emergency dismount to subject.



Guide subject onto treadmill.

- Do not enter the device when running belt is rotating.
- Do not step on rear roller.
- Do not stand on or enter the running deck when device is in elevation (running belt might slip through due to gravity).

If possible, the subject should hold both handrails for stability when entering the treadmill (running belt might slip through due to gravity).

Holding handrails during use affects exercise results. (running belt might slip through due to gravity).





Where applicable: Explain and apply fall prevention device as described in “fall prevention”.

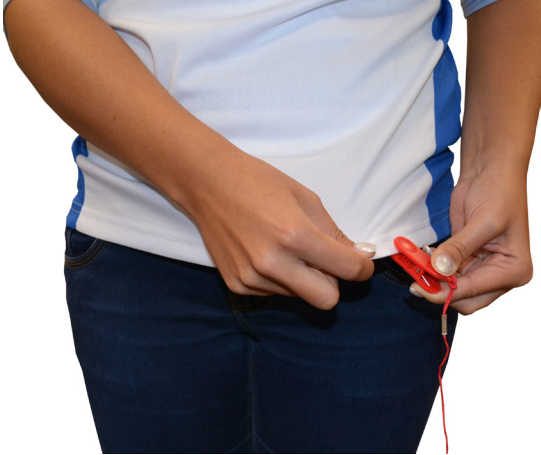

Description	Illustration
<p>Apply pull-cord safety stop. (Attach clip to subject clothing.)</p> <p>Adjust the length of the cord so that the subject has to maintain the correct position (see “position of subject and operator”). Perform a functional check.</p>	

### 5.1 Preparation of optional adjustable handrails and therapist seats

Description	Illustration
<p>Adjustment of handrails</p> <ul style="list-style-type: none"> <li>■ Pull lever</li> <li>■ Push button</li> <li>■ Adjust handrails</li> <li>■ Release button</li> <li>■ Push lever</li> </ul>	
<p>Adjustment of therapist seats</p> <ul style="list-style-type: none"> <li>■ Release fixation</li> <li>■ Adjust seat</li> <li>■ Tighten fixation</li> </ul>	
<p>Adjustment of foot rest</p> <ul style="list-style-type: none"> <li>■ Release fixation</li> <li>■ Adjust foot rest</li> <li>■ Tighten fixation</li> </ul>	



## 6 UserTerminal

### 6.1 General Description

Overview UserTerminal:





## 6.2 Standard vs. “It” devices

Most h/p/cosmos treadmills are available as standard or “It” (light) devices.

“It” devices have no UserTerminal (no display, no keyboard).

Standard device	“It” device
Control via <ul style="list-style-type: none"><li>- UserTerminal</li><li>- Software (see “accessories”)</li><li>- additional keyboard (see “accessories”)</li><li>- ECG, spirometry, etc. (see “compatible devices”)</li></ul>	Control via <ul style="list-style-type: none"><li>- Software (see “accessories”)</li><li>- additional keyboard (see “accessories”)</li><li>- ECG, spirometry, etc. (see “compatible devices”)</li></ul>

## 7 Position of Subject and Operator

1) Position of subject (initial contact)

1a) Optimal position	40%, front	running area
1b) Tolerated position	30%, middle	
1c) Not tolerated position / buffer zone	30%, rear	

2) Intended position of operator

The operator must be within reach of the emergency stop at all times.

If the operator is not able to reach the emergency stop button at the UserTerminal (body height, obstacles, etc.), the operator must install an additional emergency stop within reach (see accessories).

- |                        |                      |  |   |
|------------------------|----------------------|--|---|
| 3) Training area       | acc. to ISO 20957-1  | subject + device                       |   |
| 4) Free area           | acc. to ISO 20957-1  | training area + 0.6 m                  | must be free at all times (except operator) |
| 5) Safety area         | acc. to DIN EN 957-6 | 2.0 m behind device                    | must be free at all times (except operator) |
| 6) Patient environment | acc. to IEC 60601-1  | device + 1.5 m to all sides and height |   |



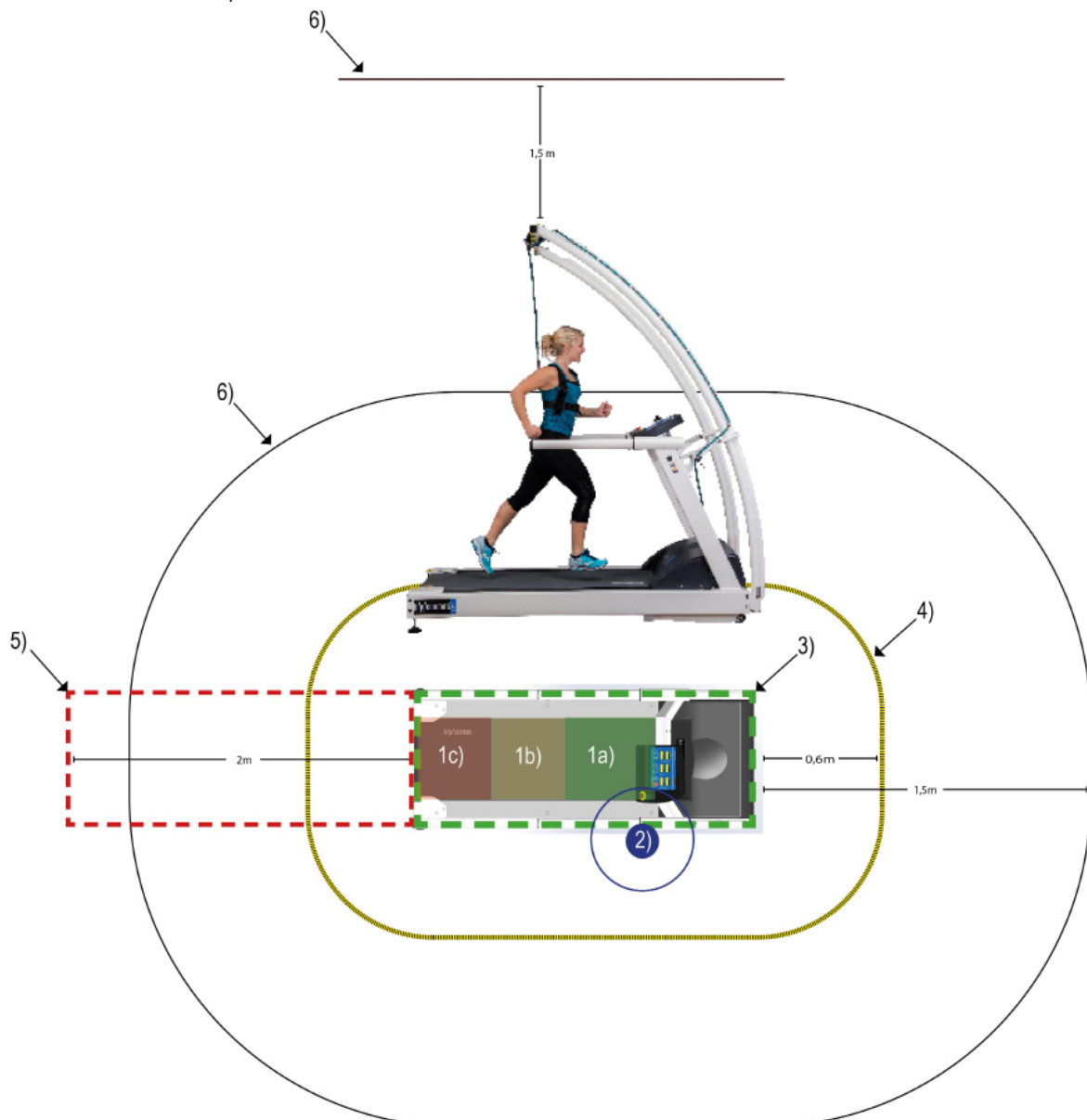

There must be no electrical devices within this area, which are not part of an ME-System with the device.

Do not touch the subject and external electrical devices at the same time.



## 8 Operation

### 8.1 General application procedure

Description	Illustration
<p>Disinfect the device (see "cleaning").</p> <p>Disconnect the device and all accessories from mains power supply before cleaning or disinfection.</p>	
<p>Make sure...</p> <ul style="list-style-type: none"><li>...the PE-cable is connected to electrical installation and device,</li><li>...the device is directly plugged into the dedicated wall socket,</li><li>...the device protection switch on the front of the device is switched on (light on),</li><li>...all emergency stops are released.</li></ul>	
<p>Switch the running machine on with the on/off switch on the UserTerminal (light goes on).</p> <p>Make sure the space under the treadmill is free from persons, body parts or objects, especially when switching on (treadmill will lower during initialization) and when changing the elevation.</p> <p>Normal condition: When starting, all displays show "0"-values.</p>	
<p>Press "enter" for quick start or select an operation mode with "prog" and "enter".</p>	
<p>Perform application.</p>	<p>-</p>
<p>Disinfect the device (see "cleaning").</p> <p>Disconnect the device and all accessories from mains power supply before cleaning or disinfection.</p>	

## 8.2 Overview of operation modes

For control, remote control and supervising purposes the free PC software para control is available on [www.hpcosmos.com](http://www.hpcosmos.com).

### Manual mode

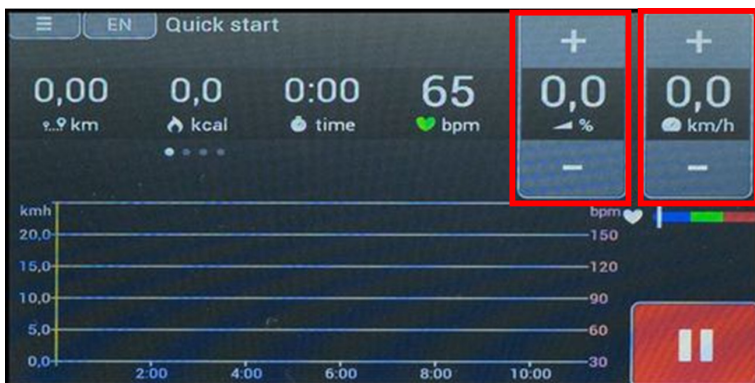

Press "+" or "-" for more or less speed

Press "+" or "-" to set the elevation

The quick start program allows an immediate workout start. No programming is required. Using the +/- buttons, the speed can be varied at all times. Using the Scan button, the figures and the graphical displays vary. Pressing the "Pause" button will initiate a display of the results as well as concludes the program.

### Reverse belt rotation (downhill)

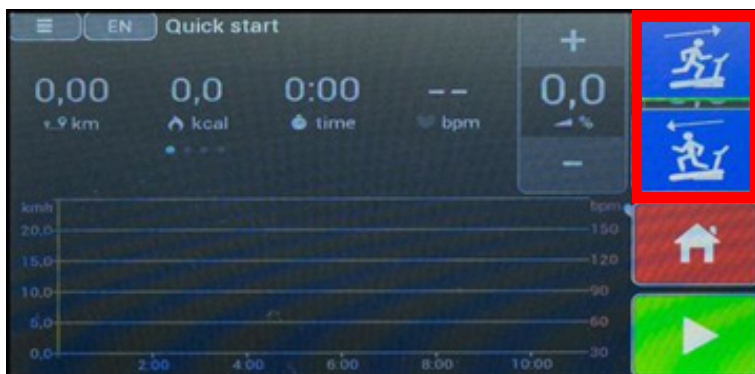

### Cool down

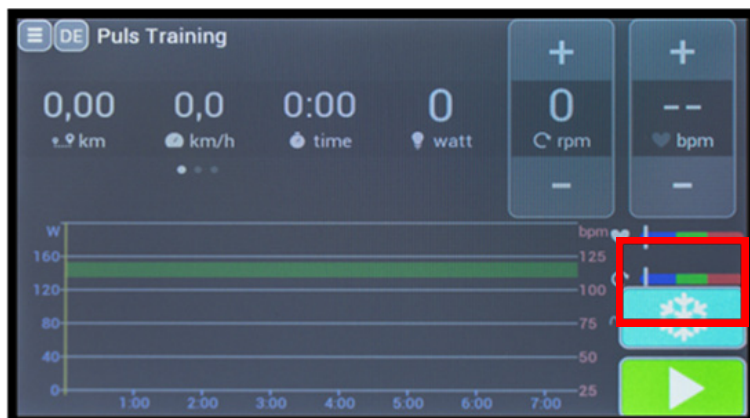

## Pulse training (%)



The pulse training option is an intelligent training program that ensures a workout intensity that is optimal for reaching training goals without the need of manual interference. The desired target heart rate (depending on the desired training aim) must be entered at the beginning of the workout. The ergometer then adjusts the resistance to the actual heart rate in a manner that allows the target heart rate zone to be reached, but not exceeded. Additionally, the program can evaluate the development of the heart rate and use the determined fitness level to adjust the speed (or incline), which allows for an optimal warm-up. If the initial resistance is set above a certain speed (with the SL optionally the incline), no warm-up will be done and the speed is immediately being adjusted to the desired heart frequency (see motion pulse manager brochure). The pulse program requires three figures to work properly

- Desired heart frequency during the workout
- Initial intensity in km/h (or with the SL the speed or incline)
- Training time in the effective heart rate range

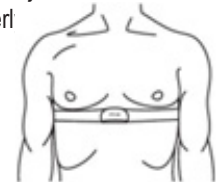

Everything else is managed by the program control. The time entered is the time of workout in the effective heart rate range, which means that the time of the warm-up will not be counted. The +/- buttons are always active during the workout.

If the initial intensity is increased to more than 8,0 km/h during the first two minutes of the workout, the program control will increase the intensity immediately to reach the target heart rate as quickly as possible. By doing so, the user can perform a so-called cross training, whereby the speed adjusts to the expected target speed during the workout and the ergometer will simply make fine tunings to the resistance.

In this program the biofeedback function is active to give the trainer and the user a visual feedback when undercutting or over-exceeding the target heart rate. Once the target heart rate has been reached, the +/- buttons can be used to change the target heart rate.

At the conclusion of the training, the results are shown on the display.

## 8.3 Manual mode / Quick start

Basic functions	Buttons / displays	Further information
-----------------	--------------------	---------------------

Select "Manual - Quick start".

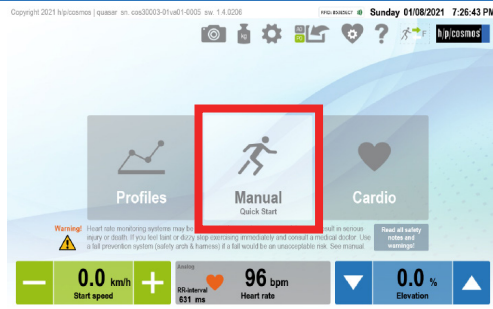

Device must be in "mode selection".  
To get there, cancel all other activities by pressing the "stop"-button.

After the countdown the treadmill starts with the preset starting speed (default = 0.5 km/h).

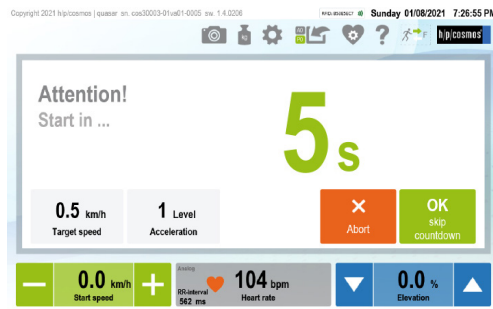

With a click on "ok" the countdown can be skipped.  
A click on "abort" ends the manual mode. The treadmill does not start.  
Adjustment of countdown settings see "options".

Confirm with "OK"  
Running belt starts with predefined starting speed (default = 0.5 km/h).



The target speed and acceleration levels can be set by clicking the button in the middle of the Touch Terminal.  
Decelerate to 0 km/h to pause the operation (see "pause function").  
Adjustment of starting speed / acceleration see "options"

This button always displays the current heart rate.



With a click on the button you can set a target heart rate. You can also switch directly to Cardio mode.

Adjust elevation:  
Press "up" ▲ or "down" ▼.  
Current elevation is displayed.



The target elevation can be set by clicking the button in the middle of the Touch Terminal.

Terminate the operation with "stop"

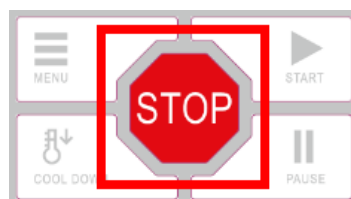



## 8.4 Profile mode



- For medical application the automatic modes must only be performed on the prescription of the medical doctor.
- Operator and subject have to be aware of automatic load changes during profile, cardio and test mode.

Start and load changes within the automatic modes are indicated by acoustic signals (beep).

Furthermore, the displays show the next load parameters (flashing).

The profile mode covers six load profiles, representing interval training sessions.

Scaled profiles cannot be stored. For self-defined tests see “test mode”.

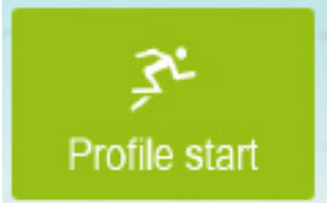
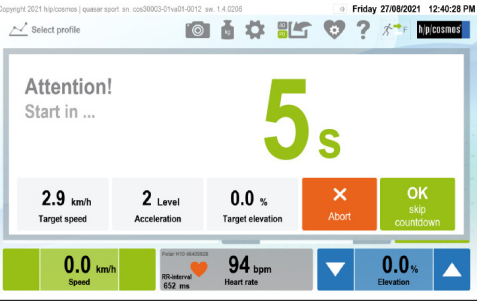
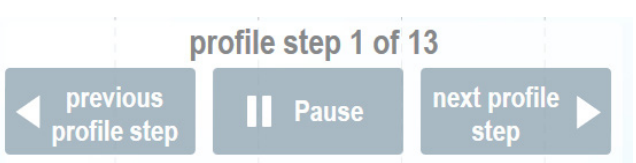
Basic functions	Buttons / displays	Further information
<p>Select “profile mode” with “&lt;” or “&gt;” button. Selected mode flashes.</p>		<p>Device must be in “start selection”. To get there, cancel all other activities by pressing the “stop”-button.</p>
<p>Profile can be scaled in predefined time, maximum speed and maximum incline by pressing buttons up and down.</p>		<p>Import your own profile using these buttons and a USB stick.</p> 
<p>Confirm with “Profil Start”.</p>		
<p>Selected profile starts with the first profile step after countdown. Operation stops automatically after the last step.</p>		
<p>Choose between previous profile step or next profile step, next profile step or pause the profile.</p>		

While the profile is running, you can see the elapsed time and distance as well as the burned kcal. With a click on the gear wheel it is possible to change the target settings at any time.



If you are in the menu to change the target settings, there is a button called "change display" in the upper right corner. The parameters to be displayed can be changed in this way.

After the profile has been completed, you will receive a summary of the training. Here you have several possibilities to save the profile.

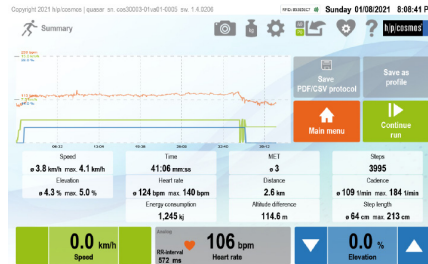

Possible is an export of CSV files, a PDF file, it is possible to convert the profile to a time profile or to a distance profile.

Terminate the operation with "stop".



For possibilities to interfere with an automatic program, see "interfere with an automatic program".



## 8.5 Cardio mode

- WARNING! Heart rate monitoring systems may be inaccurate.
- Incorrect or over exercising may result in serious injury or death.
- If you feel faint or dizzy stop exercising immediately and consult a medical doctor.
- Further exercise test stop criteria see guidelines for various treadmill exercise and treadmill tests.
- Exclude overloading or overstressing of the subject.
- For medical application the automatic modes must only be performed on the prescription of the medical doctor.
- Operator and subject have to be aware of automatic load changes during profile, cardio and test mode.
- In case of any visible or assumed defects or malfunctions (of the device, accessories, software, etc.), unplug device, exclude reconnection, mark clearly and inform h/p/cosmos service personnel via telephone and writing.

Start and load changes within the automatic modes are indicated by acoustic signals (beeps).  
Furthermore, the displays show the next load parameters (flashing).

The cardio mode allows training within pre-defined heart rate limits.  
In order to stay within the limits, the treadmill adjusts speed and elevation automatically, first speed, then elevation.

A POLAR heart rate sensor detects the heart rate.  
Moisten the contact areas of the POLAR heart rate sensor.  
Place the transmitter directly under the pectoral muscle (see picture).

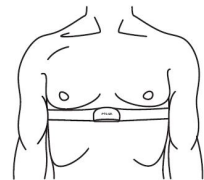

Basic functions	Buttons / displays	Further information
-----------------	--------------------	---------------------

Select "cardio".

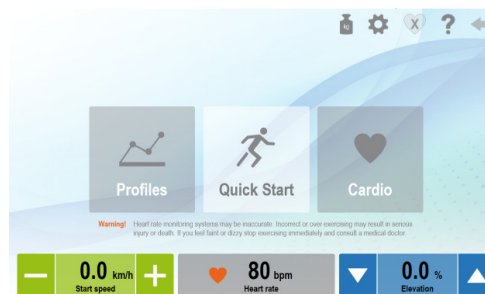

Device must be in "mode selection".  
To get there, cancel all other activities by pressing the "stop"-button.

Set

- age,
- max. speed,
- target heart rate
- start speed

Confirm each parameter with "enter".

The running belt starts automatically.



To avoid high speed, set a low max. speed. The treadmill will adjust the load via elevation.

In order to avoid elevation, set a high max. speed. The treadmill will adjust the load via speed.

Terminate the operation with "stop".



If the heart rate signal totally fails, an acoustic warning signal occurs and the heart rate display shows no value any more. Furthermore, the device reduces speed and elevation to 0 within one minute.

For possibilities to interfere with an automatic program, see “interfere with an automatic program”.

The treadmill adjusts speed and elevation according to following matrices.

Deviation from lower limit	Speed (km/h)	Elevation (%)	Reaction time (s)
< 5 heart beats	0.2	0.1	25
6 ... 15	0.4	0.2	25
16 ... 30	0.6	0.4	25
31 ... 50	0.8	0.8	20
> 50 heart beats	1.0	1.0	20

Deviation from upper limit	Speed (km/h)	Elevation (%)	Reaction time (s)
< 5 heart beats	0.3	0.3	12
6 ... 15	0.8	0.8	12
16 ... 30	1.0	1.0	10
31 ... 50	1.5	1.2	8
> 50 heart beats	2.0	1.6	7

The indicated exercise data do not remain through restart or in case of power failure. It is possible to save the exercise data on an external USB stick. The minimum resolution is 1/s.

## 8.6 Test mode

- WARNING! Heart rate monitoring systems may be inaccurate.
- Incorrect or over exercising may result in serious injury or death.
- If you feel faint or dizzy stop exercising immediately and consult a medical doctor.
- Further exercise test stop criteria see guidelines for various treadmill exercise and treadmill tests.
- Exclude overloading or overstressing of the subject.
- During stress tests a medical doctor has to be available at any time.
- For medical application the automatic modes must only be performed on the prescription of the medical doctor.
- Operator and subject have to be aware of automatic load changes during profile, cardio and test mode.
- In case of any visible or assumed defects or malfunctions (of the device, accessories, software, etc.), unplug device, exclude reconnection, mark clearly and inform h/p/cosmos service personnel via telephone and writing.

Start and load changes within the automatic modes are indicated by acoustic signals (beeps).

Furthermore, the displays show the next load parameters (flashing).

The h/p/cosmos treadmills are equipped with pre-defined tests.

- As described before, the treadmill contains a number of standardized protocols. Nevertheless, the treadmill does not give recommendations for treatment. The decision about the correct load is the duty of the medical doctor. Depending on the application the load includes speed, elevation, distance, heart rate, body weight or motion support etc..

The annex covers a detailed explanation of all pre-defined tests (see “Annex II”).

The annex also covers a detailed explanation how to create a self-defined test.

No.	Description	No.	Description
01	UKK 2km walk test	06	Ellestad A protocol
02	Conconi test	07	Ellestad B protocol
03	Graded test	08	Cooper protocol
04	Gardner test protocol	09	Balke protocol
05	Naughton protocol	10	Fitkids

### Basic functions      Buttons / displays      Further information

Select “profiles”.

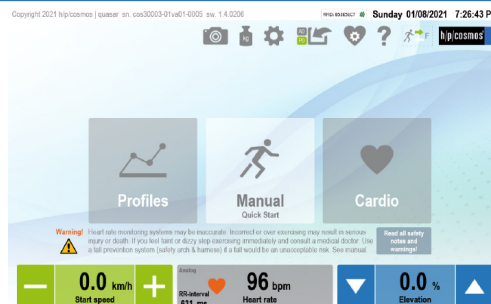

Device must be in “mode selection”. To get there, cancel all other activities by pressing the “stop”-button.

At the top left corner you can choose between profiles and tests. Select "tests".

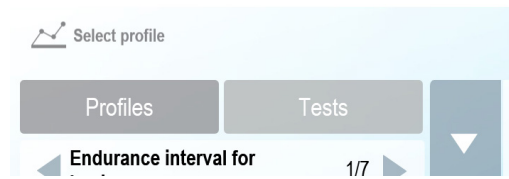

Select test with "<" or ">"

Confirm with "Start".

The running belt starts automatically after countdown.

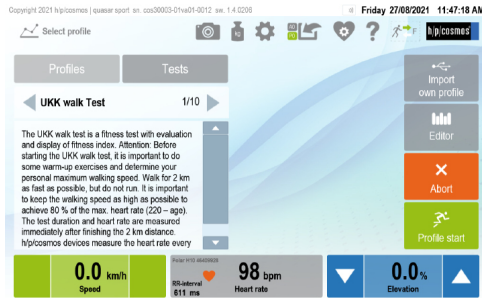

Terminate the operation with "stop".



For possibilities to interfere with an automatic program, see "interfere with an automatic program".

# 8.7 Interfere with automatic program

Basic functions	Buttons / displays	Further information
-----------------	--------------------	---------------------

Adjust speed  
Press “+” or “-”.



Profile / test mode:  
Only valid for current step.  
Cardio mode:  
Reduce the speed with “-” or exceed the max. speed with “+”;  
This sets a new max. speed

Adjust elevation:  
Press “up” ▲ or “down” ▼.



Profile / test mode:  
Only valid for current step.

Profile or test mode:  
Switch between steps

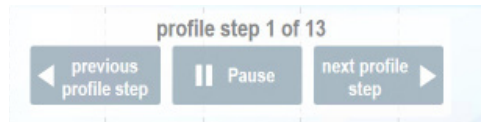

Cardio mode only:  
Change heart rate upper limit  
Press grey button "Heart rate".

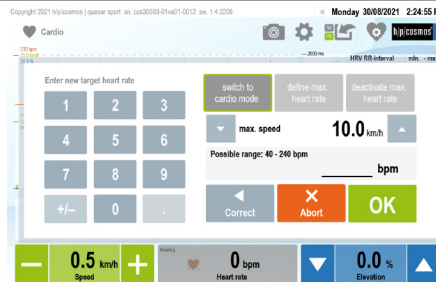

Heart rate lower limit follows according to initial range.

## 8.8 Pause function

The “pause” button on the keyboard, triggers the “pause” function.  
Treadmill reduces the speed with the set acceleration level to 0 km/h.  
The time does not stop.



The “pause” button in the profile / test mode, pauses the current profile step.  
The Treadmill will continue to run, but will not change speed or incline.



## 8.9 Acceleration levels

Start the use of the treadmill with slow walking, especially for beginners.

There are seven acceleration / deceleration levels for any kind of operation.

In order to access a certain acceleration level press the "+" or "-" button several times, then hold it.

The number of times the button is pressed before holding defines the acceleration level.

Example: Pressing "+" 3 times, then holding "+" results in an acceleration with acceleration level 3.

Acceleration levels 1 - 4 are freely accessible.

Acceleration levels 5 - 7 are locked by the administrator option OP 143. For access, please contact our service department.

The high acceleration of the levels 5 - 7 is dangerous for untrained subjects and must only be applied during sports medicine and athletic use.

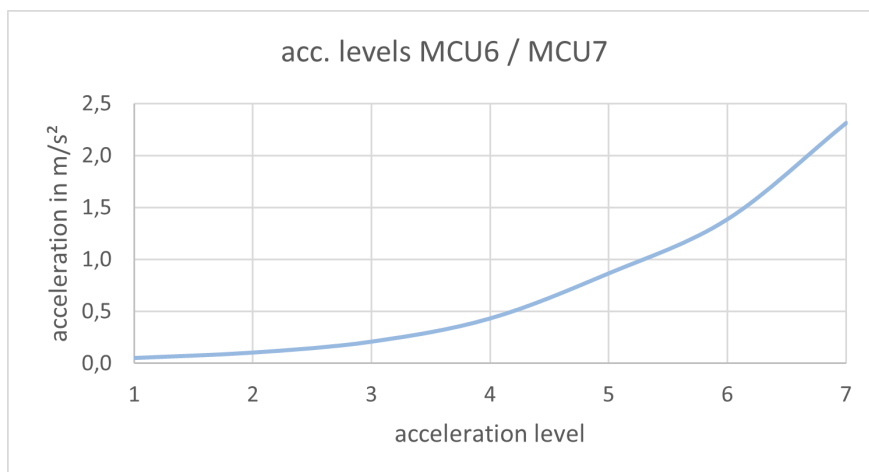

In order to limit the accessibility of the acceleration levels, see OP 246 "maximum acceleration level".

acceleration level	acceleration in m/s <sup>2</sup>
1	0.053
2	0.105
3	0.210
4	0.434
5	0.868
6	1.389
7	2.315







## 8.10 Options

### User Options

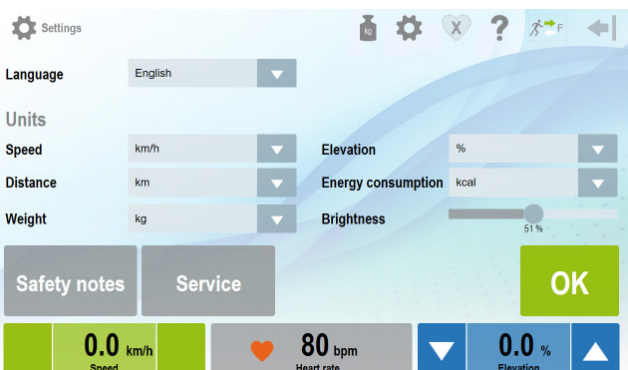
Buttons / displays	Basic functions
	<p>Click on the  to open the settings.</p> <p>In the quick selection the following things can be changed:</p> <ul style="list-style-type: none"><li>- Language</li><li>- Speed</li><li>- Distance</li><li>- Weight</li><li>- Elevation</li><li>- Energy consumption</li><li>- Brightness</li></ul>

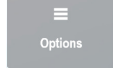
### Owner Options

Buttons / displays	Basic functions
	<p>Click on the  to open the settings.</p> <p>Click on the  button to see the overview of options.</p> <p>Click on the  button to see all owner options.</p> <p> With a click on the lock, the password can be entered. The password is: 2070 After successful decryption the owner options can be changed.</p>



## 9 Accessories / compatible devices

- Do not modify the device, configurations, accessories or software in any way.
- Do not connect any devices, accessories or software, not listed in "accessories / compatible devices".

Read and obey all instructions for use of all accessories and compatible devices.

The list of accessories / compatible devices may vary.

Therefore always refer to the most recent version of these instructions for use, available at [www.hpcosmos.com](http://www.hpcosmos.com).

### 9.1 Creating Systems

The person combining a medical device with any other device for the first time becomes manufacturer of a Medical Electrical System (ME-System acc. to IEC 60601-1, 16).

Depending on the combination, this system might even be a Programmable Electrical Medical System (PEMS acc. to IEC 60601-1, 14). It is obligatory to perform a risk management when creating an ME-System / PEMS.

Risk management, safety, compliance, and maintenance are the responsibility of the manufacturer of the ME-system / PEMS, not the responsibility of h/p/cosmos.

Devices within an ME-Systems / PEMS have to be connected with PE (potential equalization) cable in star connection.

Connect PE cable before mains plug (reconnect after maintenance).

Furthermore, the person who puts devices bearing the CE marking together, must ensure that the devices and system meet the corresponding requirements, stated in the European Medical Device Directive (MDD 93/42/EEC, Article 12).

### 9.2 Overview of accessories

Following accessories are available for this device:

(For additional options, accessories, illustrations and detailed descriptions, see annex or [www.hpcosmos.com](http://www.hpcosmos.com) and official price list)

Article number	Accessory	Purpose	Information
cos10079-01	Safety arch with chest belt harness	Fall prevention and safety stop	Optional
cos15866-01	Fall prevention system for ceiling mount with emergency stop	Fall prevention and safety stop	Optional
cos15866-01ws	Fall prevention system for ceiling mount without emergency stop	Fall prevention and safety stop	Optional
cos101729-01	Rope 10m (replacement) for fall prevention for [cos15866-01] & [cos15866-01ws]	Fall prevention and safety stop	Optional
cos10670-02	rope for safety arch 4.3m D=11.9mm	Fall prevention and safety stop	Optional
cos14903-03-XXS	Harness/chest belt size XXS (45 ... 65 cm)	Fall prevention and safety stop	Optional
cos14903-03-XS	Harness/chest belt size XS (55 ... 75 cm)	Fall prevention and safety stop	Optional
cos14903-03-S	Harness/chest belt size S (65 ... 95 cm)	Fall prevention and safety stop	Optional
cos14903-03-M	Harness/chest belt size M (85 ... 115 cm)	Fall prevention and safety stop	Optional
cos14903-03-L	Harness/chest belt size L (105 ... 135 cm)	Fall prevention and safety stop	Optional
cos14903-03-XL	Harness/chest belt size XL (125 ... 155 cm)	Fall prevention and safety stop	Optional
cos101699-03	Magnet with ripcord & plastic clip for safety stop	Safety stop	Included
cos15933	Emergency stop-button with magnet holder + 5 m spiral cable	Safety stop	Optional
cos100548	Emergency stop-button with magnet holder + 10 m spiral cable	Safety stop	Optional

Article number	Accessory	Purpose	Information
cos30028	airwalk ap unweighting device	Body weight support	Optional
cos103651	Handrail speed pluggable	Body weight support	Optional
cos100742	Handrails detachable for 3D motion analysis	Body weight support	Optional
cos102560	Arm supports for handrails adjustable	Body weight support	Optional
cos12013-01	Arm support adjustable in height and width	Body weight support	Optional
cos10107	Optional quick stop button right for arm support	Quick stop	Optional
cos10108	Optional quick stop button left for arm support	Quick stop	Optional
cos100680	Additional keyboard with spiral cord	Operation	Optional
cos10111-01	Mount for additional keyboard on arm supports	Operation	Optional
cos14135	Holder for optional keyboard on handrail (Ø 60)	Operation	Optional
cos100815	Additional keyboard with magnet holder	Operation	Optional
cos100973	Utility tray on handrail for accessories	Storage	Optional
cos11020	Drink-bottle holder for handrail 60mm	Storage	Optional
cos30022	Robowalk® expander F	Motion support / resistance	Optional
cos101355va07	Mounting-bracket-set robowalk® expander front	Motion support / resistance	Optional
cos30022-02va04	Robowalk® expander front airwalk® ap	Motion support / resistance	Optional
cos30023	Robowalk® expander B	Motion support / resistance	Optional
cos101051-XS	Leg cuff shank XS, 1 pair	Motion support / resistance	Optional
cos101050-S	Leg cuff thigh S, 1 pair	Motion support / resistance	Optional
cos101050-M	Leg cuff thigh M, 1 pair	Motion support / resistance	Optional
cos101050-L	Leg cuff thigh L, 1 pair	Motion support / resistance	Optional
cos101748	Universal noose robowalk	Motion support / resistance	Optional
cos103928	Footboard, right, extra wide (speed)	Speed training	Optional
cos103852	Floor protection mat treadmill 40x30	Floor protection, stability	Optional
cos14664-03	Wheelchair ramp (L: 130 cm x W: 101 cm)	Wheelchair access	Optional
cos10223	Potential equalization cable	Potential equalization	Optional
cos102488_iph_vesa	Smartphone holder for MCU6 UserTerminal	Connectivity	Optional
cos102488_vesa	Tablet holder MCU6 UserTerminal	Connectivity	Optional
cos102488_vesa_d	USB connection cable SmartPhones	Connectivity	Optional
cos00097010034	Interface connection cable RS 232 5m	Connectivity	Included
cos00097010035	Interface connection cable RS 232 10m	Connectivity	Optional

Article number	Accessory	Purpose	Information
cos11889	Interface connection cable RS 232 15m	Connectivity	Optional
cos11889_20m	Interface connection cable RS 232 20m	Connectivity	Optional
cos11889_25m	Interface connection cable RS 232 25m	Connectivity	Optional
cos12769-01	USB-RS232 converter	Connectivity	Optional
cos101277	Science port speed output TTL	Measurement	Optional
cos16320	Network cable RJ45, Cat.6 grey 1m	Connectivity	Optional
cos15605	Network cable RJ45, Cat.5 grey 2m	Connectivity	Optional
cos15607	Network cable RJ45, Cat.5 grey 5m	Connectivity	Optional
cos15608	Network cable RJ45, Cat.5 grey 10m	Connectivity	Optional
cos15609	Network cable RJ45, Cat.5 grey 20m	Connectivity	Optional
cos14970-03	h/p/cosmos satellite PC med	Measurement, external control	Optional
cos15686-01	h/p/cosmos satellite Notebook	Measurement, external control	Optional
cos13476-01	DELL Laptop Computer	Measurement, external control	Optional
cos104188	WiFi Adapter for MCU6 UserTerminal	Measurement	Optional
cos103625	Bluetooth Adapter for MCU6 UserTerminal	Measurement	Optional
cos101787-01a	POLAR Heart RateSensor H10 (chest belt)	Measurement	Included
cos101787_OH1	POLAR Heart RateSensor OH1 (arm belt)	Measurement	Optional
cos15178	POLAR Sender T34 Set (extended Range)	Measurement	Optional
cos102999_XXX-XX	gaitway 3d biomechanics upgrade 3 components force and torque measurement (Fx, Fy, Fz)	Measurement	Optional
cos102999_XXX	Elevation 0% to +20% for gaitway® 3D	Measurement	Optional
cos103752vaXX	Portable baseplate gaitway 3d with wheels for gaitway	Measurement	Optional
cos103971	Wheels for gaitway incline module for gaitway	Measurement	Optional
cos102999ip	Noraxon Package 3D Force and Pressure treadmill	Measurement	Optional
cos102999ds	Digital data streaming interface module	Measurement	Optional
cos103678	zebris® FDM pressure measuring platform 2i	Measurement	Optional
cos103566	zebris® FDM pressure measuring platform 3i	Measurement	Optional

Article number	Accessory	Purpose	Information
cos102999e	zebris FDM flat cable gaitway3D	Measurement	Optional
cos100385d	zebris® HS SyncCam (camera without stand)	Measurement	Optional
cos100385a	zebris® SyncLightCam (camera and LED light without stand)	Measurement	Optional
cos100385b	zebris® stand for SyncCam or SyncLightCam (mobile)	Measurement	Optional
cos100384	zebris® FDM-Stance Module	Measurement	Optional
cos101291	zebris® visual stimulation upgrade (Rehawalk®)	Measurement	Optional
cos101062	zebris® software-module virtual training (without monitor!)	Measurement	Optional
cos102521	zebris® module editor virtual training "forest walk"	Measurement	Optional
cos103312	USB 3.0 glass fiber cable A/A 20 m	Measurement	Optional
cos102397	LCD monitor TV 50" (with small monitor stand)	Measurement	Optional
cos101624	Monitor stand mobile for LCD TV 32-60"	Measurement	Optional
cos101627	Wall mount for LCD monitor TV 32-65"	Measurement	Optional
cos102065	Optogait Kit 1m single meter	Measurement	Optional
cos103386	Optofix	Mounting of Optojump / Optogait	Optional
cos10071-v6	para control 6	Software	Optional
cos101000_speed_control	SpeedControl	Software	Optional
cos101000_bluetooth	Bluetooth Heartrate Stick	Software	Optional
cos101000_wifi	WLAN / WIFI module for MCU6	Software	Optional
cos101000_FTMS	Bluetooth FTMS Interface for MCU6	Software	Optional
cos101000_step	Module step-detection for MCU6	Software	Optional
cos101000_NFC	NFC/RFID module MCU6 treadmill/ergometer	Software	Optional
cos101000_reverse	Reversing treadmill belt rotation MCU6	Software	Optional
cos101000_sound	Sound Modul for MCU6 treadmill/ergometer	Software	Optional
cos101000sw_pert-V1.0	h/p/cosmos Perturbations Software MCU6	Software	Optional

## 9.3 Compatible devices

All h/p/cosmos treadmills can be combined with the h/p/cosmos airwalk ap unweighting devices [cos30028].

A number of devices as well as software products are compatible with h/p/cosmos treadmills via coscom v4 interface protocol. Please contact [service@hpcosmos.com](mailto:service@hpcosmos.com) for the list of compatible devices.

The risk management of this device covers the influence of the compatible devices on this device.

The risk management of this device does not cover the influence of this device on the compatible devices.

Make sure, this device is listed as compatible device in the instructions for use of the compatible device.

### CAUTION / WARNING!

Do not connect and/or combine devices, options and/or accessories which are not explicitly listed and declared as compatible.

For medical applications use only IEC 60601-1 approved medical devices and IEC 60601-1 approved system configurations!

## 10 Disinfection / Cleaning

- Disinfect the device before and after every treatment.
- Disconnect the device and all accessories from mains power supply before cleaning or disinfection.

Description	Illustration
<p>Disinfection</p> <ul style="list-style-type: none"><li>- Unplug the device.</li><li>- Apply some disinfectant to a cloth.</li><li>- Wipe all surfaces the subject might have touched.</li><li>- Wipe all surfaces that may have come into contact with body fluids.</li><li>- Wipe the safety harness.</li></ul> <p>h/p/cosmos recommends Bacillol, order number [cos12179].</p>	
<p>Clean the device regularly</p> <ul style="list-style-type: none"><li>- Unplug the device.</li><li>- Use a damp cloth (not wet).</li><li>- Wipe all surfaces.</li><li>- Wash safety harness acc. to label.</li></ul>	

The h/p/cosmos devices are neither sterile nor can they be sterilized.

## 11 Maintenance

- Obey the maintenance intervals claimed in chapter “maintenance”.
- Obey the competences claimed in chapter “maintenance”.
- A second person has to be present during maintenance.
- In case of any visible or assumed defects or malfunctions (of the device, accessories, software, etc.), unplug device, exclude reconnection, mark clearly and inform h/p/cosmos service personnel via telephone and writing.
- In case of any visible or assumed wear and tear (of the device, accessories, labels, etc.), unplug device, exclude reconnection, mark clearly and inform h/p/cosmos service personnel via telephone and writing. Do not change or remove any labels!
- In case of any fluid entering into the device, unplug device, exclude reconnection, mark clearly and inform h/p/cosmos service personnel via telephone and writing.

Do not perform maintenance during use.

Proper maintenance is an important pre-condition for safety, reliability, function and accuracy of the device.

Support h/p/cosmos service personnel with the documents needed.

### 11.1 Intervals and competences

Maintenance	Interval	Competence
Daily inspection	Daily	Operator
Lubrication	When OIL message occurs	Operator
Adjustment of running belt	If due	Operator
Safety and Service inspection	12 months	h/p/cosmos service personnel only
Change of safety arch rope	24 months	h/p/cosmos service personnel only
Tightening of the running belt	If due	h/p/cosmos service personnel only
Adjustment of levelling sockets	If due	h/p/cosmos service personnel only
Installation and repair work	If due	h/p/cosmos service personnel only

h/p/cosmos recommends entering into a service contract with an authorized h/p/cosmos service technician.

A service contract provides the best preventive maintenance and care for the device and include annual safety and accuracy checks..

The service contract is available at [service@hpcosmos.com](mailto:service@hpcosmos.com).

To receive information on becoming h/p/cosmos service personnel, please contact [service@hpcosmos.com](mailto:service@hpcosmos.com).

### 11.2 Daily inspection

- Perform a daily visual inspection (see chapter “maintenance”).

Before daily use, check the whole device for wear and tear.

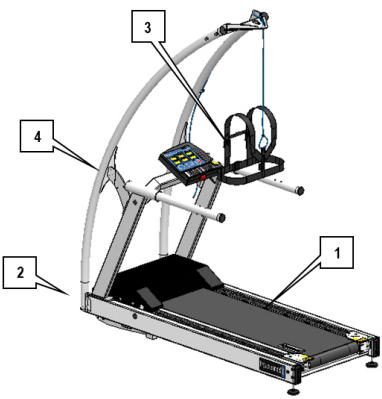
Description	Illustration
<p>Pay special attention to components with high probability of wear and tear:</p> <ol style="list-style-type: none"> <li>1. Running belt and non-slip surfaces</li> <li>2. External cabling</li> <li>3. All textile parts</li> <li>4. Fall prevention incl. safety harness, buckle, carabiner, rope and rope arrest</li> </ol> <p>If there is any visible or assumed wear and tear, unplug device, exclude reconnection and call h/p/cosmos service personnel.</p>	 <p>The illustration shows a fitness device with four numbered callouts: 1 points to the running belt, 2 points to the external cabling, 3 points to the safety harness and rope, and 4 points to the safety arch structure.</p>

Description	Illustration
-------------	--------------

- Perform a functional check of all safety equipment:
5. Fall prevention
  6. Pull cord safety stop
  7. Emergency stop button on UserTerminal
  8. Further safety equipment

If there is any visible or assumed defects or malfunctions, unplug device, exclude reconnection and call h/p/cosmos service personnel.

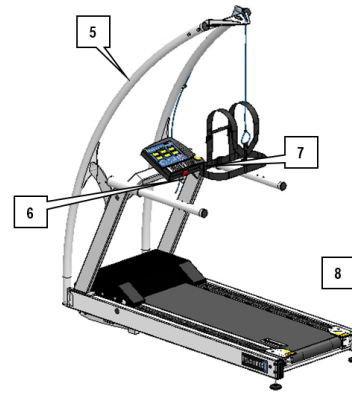

## 11.3 Lubrication

Description	Illustration
-------------	--------------

When OIL message occurs, check the oil film on the running belt. Do the same if there are dry grinding noises during operation.

The OIL messages occurs every 1000 km by default.  
The oil interval may be varied, depending on environmental conditions and use.



Unplug the treadmill.



Move one hand / tissue for 1 m through the center between running belt and running deck.

A slight film of oil must remain on the hand.  
If the running belt is too dry, it must be lubricated.

For further and precise analysis a detailed instruction regarding the tissue lubrication test is available at [service@hpcosmos.com](mailto:service@hpcosmos.com).

Fill the syringe with 10 ml of the lubricant (h/p/cosmos special oil, only).

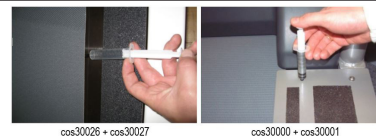

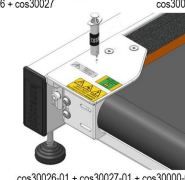

Pump the lubricant under the running belt very slowly and remove the syringe.





## 11.4 Adjustment of running belt

- Unmeant trapping hazards: Take off ties, scarfs or other clothes that may be trapped. Secure long hair and ribbons during maintenance and training in order to prevent being captured in trapping zones.
- Do not touch the running belt while it is in motion.
- A second person has to be present during maintenance.

Description	Illustration
<p>The maximum allowed lateral position of the running belt is marked with this label.</p>	 A rectangular label with a green center and yellow borders. At the top, it says "Limit" with double-headed arrows. Below that, it says "Keep the belt in the green area!". In the center is a yellow warning triangle with a black exclamation mark. At the bottom, it says "www.h-p-cosmos.com" and has a small code "[cos102456-01]" on the left.
<p>Operate the device at 10 km/h. Turn the LEFT trimming screw very slowly (¼ rotation – observe – ¼ rotation – observe...).</p> <p>Turn clockwise to adjust belt to the right. Turn counter-clockwise to adjust belt to the left.</p>	 A close-up photograph showing a person's hand using an Allen key to adjust a screw on the side of a white running machine. The machine has "h-p-cosmos" printed on it.
<p>After adjustment, observe the running belt at 10 km/h for at least 2 min. Belt must maintain the position.</p> <p>Remove Allen key from screw.</p>	 A rectangular label with a green center and yellow borders. At the top, it says "Limit" with double-headed arrows. Below that, it says "Keep the belt in the green area!". In the center is a yellow warning triangle with a black exclamation mark. At the bottom, it says "www.h-p-cosmos.com" and has a small code "[cos102456-01]" on the left.

## 11.5 Issues for qualified service personnel

All maintenance work that is not explained in detail, must not be performed by the operator.

Safety inspections, installation and repair work, must also not be performed by the operator.

This kind of work must be performed by h/p/cosmos service personnel according to the "h/p/cosmos service instructions".

The "h/p/cosmos service instructions" are available at [service@hpcosmos.com](mailto:service@hpcosmos.com).

## 11.6 Safety inspection

In order to maintain the safety of the device, h/p/cosmos prescribes performance of an annual safety inspection.

Refer to the date on the inspection sticker on your device for the next inspection date.



h/p/cosmos bases the annual safety inspection on German laws and regulations.

It is the operator's responsibility to comply with national laws and regulations.

Inspection intervals for optional equipment and accessories may deviate.

After 12 months or 5000 km there will be a safety inspection reminder (see below).

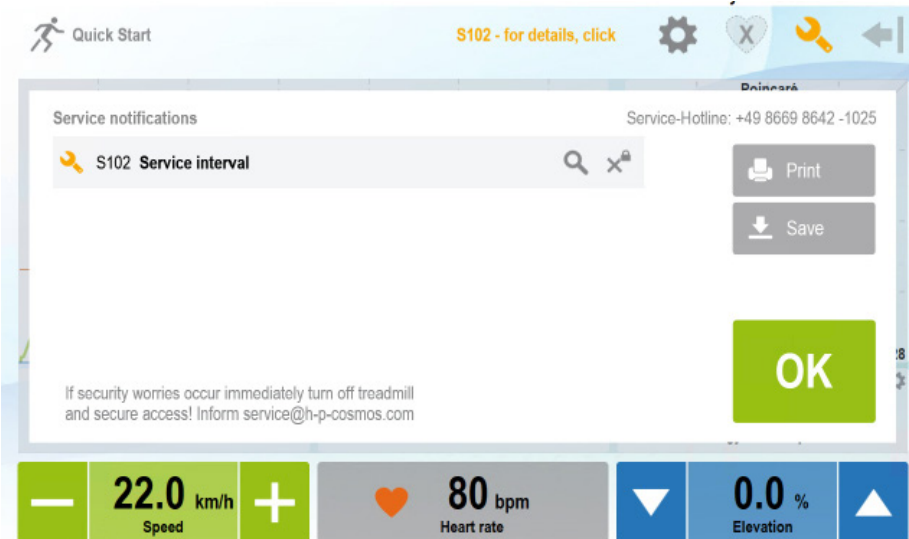

The error message will be reset by the h/p/cosmos service personnel performing the safety inspection.

A maintenance work and/or safety check cannot guarantee the safety of a device. It is only a statement of the visible and measurable parameters and conditions at the moment of the measurement.

## 11.7 Spare parts and consumables

Spare parts must only be replaced by qualified h/p/cosmos service personnel.

Information about spare parts is available at [service@hpcosmos.com](mailto:service@hpcosmos.com).

A list of consumables is included in the accompanying documents.

## 12 Troubleshooting

### 12.1 General troubleshooting

- In case of any visible or assumed defects or malfunctions (of the device, accessories, software, etc.), unplug device, exclude reconnection, mark clearly and inform h/p/cosmos service personnel via telephone and writing.
- In case of any visible or assumed wear and tear (of the device, accessories, labels, etc.), unplug device, exclude reconnection, mark clearly and inform h/p/cosmos service personnel via telephone and writing. Do not change or remove any labels!
- Use also the error report form at: <https://www.hpcosmos.com/en/products/service>

Problem	Solution
Device cannot be switched on	Release emergency stop (see “emergency stop”) Check power supply connection Check device protection switch Check power socket (test with another device)
Speed does not work	Release all emergency stops (see “emergency stop”) In case there is no improvement, contact <a href="mailto:service@hpcosmos.com">service@hpcosmos.com</a> .
Elevation does not work	Switch off Wait 10 min (in order to cool down) Switch on again In case error still appears, unplug device, exclude reconnection, mark clearly and inform h/p/cosmos service personnel via telephone and writing.
Oil leakage	Remove excess oil besides running belt Remove excess oil under running belt Check the next days and repeat if necessary. In case there is no improvement, contact <a href="mailto:service@hpcosmos.com">service@hpcosmos.com</a> .
Electrostatic discharge	Choose proper floor, clothing and humidity
Grinding noises	Contact <a href="mailto:service@hpcosmos.com">service@hpcosmos.com</a>
Running belt outside of lateral limits	See “adjustment of running belt”
Problems with heart rate measurement	See “Annex III (Accessories)” In case there is no improvement, contact <a href="mailto:service@hpcosmos.com">service@hpcosmos.com</a> .
Any other problem	Unplug device, exclude reconnection, mark clearly and inform h/p/cosmos service personnel via telephone and writing.

## 12.2 Interface troubleshooting

Problem	Solution
No connection via RS232, USB (wrong cable)	For connection to PC with h/p/cosmos software and most external devices use the included RS 232 interface connection cable [cos00097010034].
No connection via RS232, USB (cable defect)	Check cable and plugs for defects. Replace defective cable.
No connection via RS232 (wrong settings)	Choose correct interface protocol on device. Choose correct interface protocol on periphery. Check installation of peripheral software.
No connection via RS232 (blocked COM port)	Restart peripheral software. Restart peripheral device.
No connection via RS232 (RS232 connection off)	Switch on RS232 connection
Any other problem	unplug device, exclude reconnection, mark clearly and inform h/p/cosmos service personnel via telephone and writing.

## 12.3 Error messages

Following error messages may be displayed on the UserTerminal:

Error code	Error message	Action
S101	Oil Help	See "lubrication"
S102	Service Help	See "safety inspection"
S131	Speed tolerance measurement outside the limit (above)	Unplug device, exclude reconnection and contact <a href="mailto:service@hpcosmos.com">service@hpcosmos.com</a>
S132	Speed tolerance measurement outside the limit (below)	
S165	Communication interruption to external / failsafe	
E121	elevation error increments	
E130	speed error increments	
E151	FU error response	
E152	FU communication timeout	
E153	internal communication error	
E155	internal communication error response	
E156	internal communication error general	
E160	no connection (para control)	

## 13 Technical data (med)

### 13.1 UserTerminal

Description	Data
Displays	Dot-Matrix
Keyboard	Keyboard film

### 13.2 Dimensions

Description	Data
Device dimensions	L: 210 x W: 86 x H: 129 cm
Running surface dimensions	L: 150 x W: 50 cm
Track access height	23 cm
Handrail dimensions	Ø : 6 cm, L: 62 cm

Data may be influenced by accessories. Lower profile versions or custom made devices on request.

### 13.3 Loads

Description	Data
Max. subject weight *	250 kg
Device weight	240 kg
Substitutional load to floor (EN 1991)	3.3 kN / m <sup>2</sup>
Load on each support (wheels + feet)	1.5 kN

Data may be influenced by accessories. Lower profile versions or custom made devices on request.

### 13.4 Emissions

Description	Data
Heat emission	approx. 53°C (on/off and stand-by button, contact < 1 min)
A-weighted emission sound pressure level at the trainer's ear (EN 957-6)	LpA <70 dB A (63 dB) (Noise emission under load is higher than without load.)

### 13.5 Essential performance characteristics

Description	Data
Speed	0.0 ... 22.0 km/h
Min. speed increment	0.1 km/h
Speed accuracy *	± 0.1 km/h (up to 2 km/h), ± 5 % (above 2 km/h)
Elevation	0.0 ... 25.0 %
Min. elevation increment	0.1 %
Elevation accuracy *	± 10 % (above 2 % elevation)

## 13.6 Environmental conditions

Make sure no objects, sand, stones, liquids, towels, jewellery, cell phones, containers with liquid etc. can fall into the device or onto the running surface or underneath the running belt.

Operation	Data
Temperature	+10 ... +30° C (min.: -30°C max.: +50°C with optional special climate chamber design, article: cos14893-B50_1P-01)
Humidity	20 ... 85%, without condensation (max. 95%, without condensation, with optional special climate chamber design, article: cos14893-B50_1P-01)
Pressure	700 ... 1060 hPa
Altitude	max. 3000 m, without pressurization (altitudes >1000m can cause minor loss of performance)
Oxygen saturation	<= 25%
Central lubrication system	manual

Exclude presence of explosive, inflammable, acid and corrosive gases.  
Exclude high voltage lines and strong magnetic fields / devices in near vicinity.

Transport & Storage	Data
Temperature	-25°C ... +40°C
Humidity	0 ... 95%, without condensation
Pressure	700 ... 1060 hPa
Altitude	max. 3000 m, without pressurization

When storing for more than 6 months without power connection, the batteries of the MCU may discharge.  
Please contact [service@hpcosmos.com](mailto:service@hpcosmos.com) in case of re-installation after storage.

## 13.7 Technical and legal requirements

Description	Data
Stationary training equipment	ISO 20957-1, ISO 20957-6
Medical electrical equipment	IEC 60601-1
Electromagnetic compatibility	IEC 60601-1-2
Usability	IEC 60601-1-6, IEC 62366-1
Software	IEC 62304
Medical device regulation	(EU) 2017/745
Machinery regulation	(EU) 2023/1230
Legal requirements	German Medical Device Law Implementation Act (MPDG – Medizinprodukte-Durchführungsgesetz)

## 13.8 EMC tests

Description	Data	Level
Measurement of conducted RF emission	EN 55011:2016 + A1:2017 + All:2020 + A2:2021 Class A	150 kHz up to 30 MHz 56 dB $\mu\text{V}/\text{m}$ / 60 dB $\mu\text{V}/\text{m}$
Measurement of radiated RF emission	EN 55011:2016 + A1:2017 + All:2020 + A2:2021 Class A	30 MHz up to 1 GHz 40 dB $\mu\text{V}/\text{m}$ / 47 dB $\mu\text{V}/\text{m}$
Voltage fluctuations and flicker	EN 61000-3-3:2013+A1:2019	Plt = 0,65
Electrostatic discharge immunity test	EN 61000-4-2:2009	8 kV contact 15 kV air
Radiated, RF, electromagnetic field immunity test	EN IEC 61000-4-3:2020	80 MHz – 2.7 GHz / 10 V/m / 80 % AM 1 kHz / $\geq 1$ s
Radiated, RF, electromagnetic field immunity test	EN IEC 61000-4-3:2020	9 V/m, pulse 217 Hz modulation 27V/m, pulse 18 Hz modulation 28V/m, pulse 217 Hz modulation 28V/m, pulse 18 Hz modulation
Electrical fast transient immunity test	EN 61000-4-4:2012	+/- 2 kV 100 kHz
Surge immunity test	EN 61000-4-5:2014+A1:2017	+/- 2kV
Immunity to conducted disturbances, induced by radio-frequency fields	EN IEC 61000-4-6:2013	3 V 0,15 MHz up to 80 MHz
Power frequency magnetic field immunity test	EN IEC 61000-4-8:2009	30 A/m 50 Hz or 60 Hz
Voltage dips, short interruptions and voltage variations immunity tests	EN IEC 61000-4-11:2020+AC:2020	0,5 cycle 1,0 cycle 250/300 cycle
Testing of voltage changes, voltage fluctuations and flicker in public low-voltage supply systems	EN 61000-4-39:2017	30 kHz / 8 A/m 134,2 kHz / 65 A/m 13,56 MHz / 7,5 A/m

There are no deviations to the standards described above.

No special measures to be taken with regard to EMC.

The EMISSIONS characteristics of this equipment make it suitable for use in industrial areas and hospitals (CISPR 11 class A). If it is used in a residential ENVIRONMENT (for which CISPR 11 class B is normally required) this equipment might not offer adequate protection to radio-frequency communication services. The user might need to take mitigation measures, such as relocating or reorienting the equipment.

### 13.9 Wireless technologies

Description	Signal Strength	Modulation	Band
Bluetooth	+0 dBm to -27 dBm	GFSK	ISM-Bands
WIFI/WLAN	< 20 dBm EIRP for 2,4GHz < 20 dBm EIRP for 5 GHz	2412MHz-2472MHz for 802.11b, g, n/HT20 2422MHz-2462MHz for 802.11n/HT40 5180MHz-5240MHz for 802.11a 5180MHz-5240MHz for 802.11ac VHT20"	
NFC/RFID	-9dBm	ASK or BPSK	13.56 MHz
POLAR analogue heart rate transmission	Only receiver	Only receiver	5 kHz

### 13.10 Classification

Description	Data	
(EU) 2017/745	Notified body	CE 0123
(EU) 2017/745	Risk class	IIb active therapeutic device and active diagnostic device
IEC 60601-1	Protection against electric shock	Class I, ⚡
IEC 60601-1	Protection against harmful ingress of water or particulate matter	IP20
IEC 60601-1	Mode of operation	Continuous operation with intermittent loading
IEC 60601-1	Overvoltage category	II (2500 V <sub>peak</sub> mains transient voltage)
IEC 60601-1	Applied part	Type B ⚡ (whole device)
IEC 60601-1	Pollution degree	Degree 2
ISO 20957-1	Usage class	S (Studio): professional and / commercial use I (inclusive): professional and/or commercial use provided for inclusive use for people with special needs
ISO 20957-6	Accuracy class	A
IEC 62304	Risk class	B



## 13.11 Certificates

Description	Data
MDR (EU) 2017/745	CE declaration of conformity
MDR (EU) 2017/745	EC certificate, quality assurance
MDR (EU) 2017/745	Free sales certificate
EN ISO 13485	Certificate, quality management medical devices
IEC 60601-1	CB certificate
UL 60601-1	NRTL certificate

Certificates see accompanying documents and <https://www.hpcosmos.com/en/contact-support/media-downloads/certificates>

## 13.12 Interfaces

Description	Data
COM 1 RJ45 (service)	Baud rate 115200 bps
COM 2 BLE (optional)	Baud rate 9600 bps

Only coscom v3 and/or coscom v4 interface protocols are validated according to IEC 62304 if a quality assurance agreement between the involved manufacturers exists. See [www.coscom.org](http://www.coscom.org).

## 13.13 Voltage, Current, Performance

Description	Data
Input voltage *	200 V - 240 V ~ (f: 50 – 60 Hz)
Current input (long time) *	6.0 A
Current input (momentary) *	13.5 A
Energy consumption (long time)	≤ 1320 VA
Energy consumption (momentary)	≤ 2970 VA
Energy efficiency	N/A
Device protection switch (circuit breaker)	16 A
Drive motor capacity	2200 W
Elevation motor capacity	470 W
Device leakage current	≤ 0.2 mA
Isolation transformer	1840 VA
Power supply cord	detachable, 3 m

\* Overload or weak power supply may lead to reduced speed accuracy or tripping the fuse.  
Subject to technical alterations without prior notice. E & OE (errors and omissions excepted).

Note: In case of special voltage versions, the data on the name plate apply.  
Connect mains only if data on nameplate and local power supply are identical.  
Subject to technical alterations without prior notice. E & OE (errors and omissions excepted).

## 13.14 Software, Programs

Description	Data
PC Software	
h/p/cosmos para control®	included
gaitway (non medical)	optional
Noraxon (non medical)	optional
Microgate Optogait	optional
zebris Rehawalk	optional
Number of stored programmes	20 training profiles, 10 test profiles, 8 user definable profiles

For other coscom compatible software see website [www.coscom.org](http://www.coscom.org)

## 13.15 All-pole disconnection

The following options are available for all-pole disconnection:

- Unplug device from power socket.
- Unplug cable from device (if possible).
- Switch off device protection switch

Maintain enough free space to ensure access to cables and the circuit breaker (see “position of subject and operator”).

## 13 Technical data (sport)

### 13.1 UserTerminal

Description	Data
Displays	Dot-Matrix
Keyboard	Keyboard film

### 13.2 Dimensions

Description	Data
Device dimensions	L: 210 x W: 86 x H: 129 cm
Running surface dimensions	L: 150 x W: 50 cm
Track access height	23 cm
Handrail dimensions	Ø : 6 cm, L: 62 cm

Data may be influenced by accessories. Lower profile versions or custom made devices on request.

### 13.3 Loads

Description	Data
Max. subject weight *	250 kg
Device weight	225 kg
Substitutional load to floor (EN 1991)	3.3 kN / m <sup>2</sup>
Load on each support (wheels + feet)	1.5 kN

Data may be influenced by accessories. Lower profile versions or custom made devices on request.

### 13.4 Emissions

Description	Data
Heat emission	approx. 53°C (on/off and stand-by button, contact < 1 min)
A-weighted emission sound pressure level at the trainer's ear (EN 957-6)	LpA <70 dB A (63 dB) (Noise emission under load is higher than without load.)

### 13.5 Essential performance characteristics

Description	Data
Speed	0.0 ... 22.0 km/h
Min. speed increment	0.1 km/h
Speed accuracy *	± 5 % (above 2 km/h), ± 0.1 km/h (up to 2 km/h)
Elevation	0.0 ... 25.0 %
Min. elevation increment	0.1 %
Elevation accuracy *	± 5 % (above 2 % elevation)

## 13.6 Environmental conditions

Make sure no objects, sand, stones, liquids, towels, jewellery, cell phones, containers with liquid etc. can fall into the device or onto the running surface or underneath the running belt.

Operation	Data
Temperature	+10 ... +30° C (min.: -30°C max.: +50°C with optional special climate chamber design, article: cos14893-B50_1P-01)
Humidity	20 ... 85%, without condensation (max. 95%, without condensation, with optional special climate chamber design, article: cos14893-B50_1P-01)
Pressure	700 ... 1060 hPa
Altitude	max. 3000 m, without pressurization (altitudes >1000m can cause minor loss of performance)
Oxygen saturation	<= 25%
Central lubrication system	manual

Exclude presence of explosive, inflammable, acid and corrosive gases.  
Exclude high voltage lines and strong magnetic fields / devices in near vicinity.

Transport & Storage	Data
Temperature	-25°C ... +40°C
Humidity	0 ... 95%, without condensation
Pressure	700 ... 1060 hPa
Altitude	max. 3000 m, without pressurization

When storing for more than 6 months without power connection, the batteries of the MCU may discharge.  
Please contact [service@hpcosmos.com](mailto:service@hpcosmos.com) in case of re-installation after storage.

## 13.7 Technical and legal requirements

Description	Data
Stationary training equipment	ISO 20957-1, ISO 20957-6
Electrical equipment	IEC 60335-1
Electromagnetic compatibility	IEC 60335-1
Usability	IEC 60601-1-6, IEC 62366-1
Software	IEC 62304
Machinery regulation	(EU) 2023/1230

## 13.8 EMC tests

Description	Data	Level
Measurement of conducted RF emission	EN 55011:2016 + A1:2017 + A11:2020 + A2:2021	150 kHz up to 30 MHz 56 dB $\mu$ V/m / 60 dB $\mu$ V/m
Measurement of radiated RF emission	EN 55011:2016 + A1:2017 + A11:2020 + A2:2021	30 MHz up to 1 GHz 40 dB $\mu$ V/m / 47 dB $\mu$ V/m
Voltage fluctuations and flicker	EN 61000-3-3:2013+A1:2019	Plt = 0,65
Electrostatic discharge immunity test	EN 61000-4-2:2009	8 kV contact 15 kV air
Radiated, RF, electromagnetic field immunity test	EN IEC 61000-4-3:2020	80 MHz – 2.7 GHz / 10 V/m / 80 % AM 1 kHz / $\geq$ 1 s
Radiated, RF, electromagnetic field immunity test	EN IEC 61000-4-3:2020	9 V/m, pulse 217 Hz modulation 27V/m, pulse 18 Hz modulation 28V/m, pulse 217 Hz modulation 28V/m, pulse 18 Hz modulation
Electrical fast transient immunity test	EN 61000-4-4:2012	+/- 2 kV 100 kHz
Surge immunity test	EN 61000-4-5:2014+A1:2017	+/- 2kV
Immunity to conducted disturbances, induced by radio-frequency fields	EN IEC 61000-4-6:2013	3 V 0,15 MHz up to 80 MHz
Power frequency magnetic field immunity test	EN IEC 61000-4-8:2009	30 A/m 50 Hz or 60 Hz
Voltage dips, short interruptions and voltage variations immunity tests	EN IEC 61000-4-11:2020+AC:2020	0,5 cycle 1,0 cycle 250/300 cycle
Testing of voltage changes, voltage fluctuations and flicker in public low-voltage supply systems	EN 61000-4-39:2017	30 kHz / 8 A/m 134,2 kHz / 65 A/m 13,56 MHz / 7,5 A/m

There are no deviations to the standards described above.  
No special measures to be taken with regard to EMC.

The EMISSIONS characteristics of this equipment make it suitable for use in industrial areas and hospitals (CISPR 11 class A). If it is used in a residential ENVIRONMENT (for which CISPR 11 class B is normally required) this equipment might not offer adequate protection to radio-frequency communication services.  
The user might need to take mitigation measures, such as relocating or reorienting the equipment.

## 13.9 Wireless technologies

Description	Signal Strength	Modulation	Band
Bluetooth	+0 dBm to -27 dBm	GFSK	ISM-Bands
WIFI/WLAN	< 20 dBm EIRP for 2,4GHz < 20 dBm EIRP for 5 GHz	2412MHz-2472MHz for 802.11b, g, n/HT20 2422MHz-2462MHz for 802.11n/HT40 5180MHz-5240MHz for 802.11a 5180MHz-5240MHz for 802.11ac VHT20"	
NFC/RFID	-9dBm	ASK or BPSK	13.56 MHz
POLAR analogue heart rate transmission	Only receiver	Only receiver	5 kHz

## 13.10 Classification

Description	Data	
(EU) 2023/1230	CE	
IEC 60335-1	Protection against electric shock	Class I, 
IEC 60335-1	Protection against harmful ingress of water or particulate matter	IP20
IEC 60335-1	Mode of operation	Continuous operation with intermittent loading
IEC 60335-1	Overvoltage category	Life-Earth < 300 V (1500 V <sub>peak</sub> mains transient voltage)
IEC 60335-1	Pollution degree	Degree 2
ISO 20957-1	Usage class	S (Studio): professional and / commercial use I (inclusive): professional and/or commercial use provided for inclusive use for people with special needs
ISO 20957-6	Accuracy class	A

## 13.11 Certificates

Description	Data
(EU) 2023/1230	CE declaration of conformity
EN ISO 13485	Certificate, quality management medical devices

Certificates see accompanying documents and

<https://www.hpcosmos.com/en/contact-support/media-downloads/certificatesw>

## 13.12 Interfaces

Description	Data
COM 1 RJ45 (service)	Baud rate 115200 bps
COM 2 BLE (optional)	Baud rate 9600 bps

Only coscom v4 interface protocols are validated according to IEC 62304 if a quality assurance agreement between the involved manufacturers exists. See [www.coscom.org](http://www.coscom.org).

## 13.13 Voltage, Current, Performance

Description	Data
Input voltage *	200 V - 240 V ~ (f: 50 – 60 Hz)
Current input (long time) *	6.0 A
Current input (momentary) *	13.5 A
Energy consumption (long time)	≤ 1320 VA
Energy consumption (momentary)	≤ 2970 VA
Energy efficiency	N/A
Device protection switch (circuit breaker)	16 A
Drive motor capacity	2200 W
Elevation motor capacity	470 W
Device leakage current	≤ 1.0 mA
Power supply cord	detachable, 3 m

Read name plate and technical data on the machine just to make sure in case a special voltage version model has been supplied.

Connect to the mains only if data on nameplate and local power supply are identical.

\* Overload or weak power supply may lead to reduced speed accuracy or tripping the fuse.

Subject to technical alterations without prior notice. E & OE (errors and omissions excepted).

## 13.14 Software, Programs

Description	Data
PC Software	
h/p/cosmos para control®	included
gaitway (non medical)	optional
Noraxon (non medical)	optional
Microgate Optogait	optional
zebris Rehawalk	optional
	20 training profiles, 10 test profiles, 8 user definable profiles

For other coscom compatible software see website [www.coscom.org](http://www.coscom.org)

## 13.15 All-pole disconnection

The following options are available for all-pole disconnection:

- Unplug device from power socket.
- Unplug cable from device (if possible).
- Switch off device protection switch

Maintain enough free space to ensure access to cables and the circuit breaker (see “position of subject and operator”).



## 14 Liability and Warranty

Following will cause loss of liability and warranty and may result in serious injury or death or damage to the device:

- Use other than explicitly mentioned as intended use
- Unauthorized maintenance or lack of maintenance, safety checks or repairs
- Unauthorized modifications or extensions
- Unauthorized installation, commissioning or instruction
- Use of any unauthorized or non-original h/p/cosmos parts, spare parts, consumables, sensors or detectors
- Disregard of safety information (danger, warning and caution statements)
- Any unauthorized modifications to the device, software, configurations and accessories
- Connection of accessories, software or devices, not listed in “accessories / compatible devices”

The “safety information – forbidden use” list does not claim to be exhaustive and may be extended during market phase (post market surveillance). The latest version of these instructions for use is always available at: [www.hpcosmos.com](http://www.hpcosmos.com)

Limited liabilities apply:

If h/p/cosmos or h/p/cosmos organizational bodies, senior management or agents can be held accountable for the payment of damages pertaining to slight negligence (breach of material contractual obligations), the damages shall be limited to damages that could typically have been foreseen. Liability pertaining to slight negligence excludes liability as a result of loss of production, interruption of business and loss of profits.

Further details see website: [www.hpcosmos.com/en/gtcb](http://www.hpcosmos.com/en/gtcb).

## 15 Expected Lifetime

- Obey the maintenance intervals claimed in chapter “maintenance”.
- Obey the competences claimed in chapter “maintenance”.
- The expected lifetime of the entire device (except the PC, computer hardware and software) is 10 years, provided, that all maintenance intervals are maintained.
- wear and tear parts are replaced by h/p/cosmos service personnel during applicable maintenance intervals and/or earlier at the first sign of wear and tear.
- The expected lifetime of the device may be significantly reduced in case of harsh environmental conditions (e.g. climate chamber applications) and/or in case of excessive use.  
Perform annual maintenance and safety checks through h/p/cosmos authorized and trained personnel for continuous monitoring of the safety and condition of the device.

The expected lifetime of the PC incl. touch panel, computer hardware and software is 5 years.

By replacing all electric and electronic components after 10 years, the lifetime of the treadmill (except the PC, computer hardware and software) may be extended by another 10 years (=total 20 years from date of manufacturing).

Devices with electric power supply should be replaced at the latest after 20 years of age or earlier in case of visible damages, wear and tear due to possible hidden isolation risks, electric shock, etc..

See also expert statement regarding Lifetime of a medical device – end of life:

<https://www.hpcosmos.com/en/news/lifetime-medical-device-end-life>

[https://www.hpcosmos.com/sites/default/files/20210219\\_mp-recht\\_luecker\\_hpcosmos\\_lifetime\\_of\\_a\\_medical\\_device\\_lr.pdf](https://www.hpcosmos.com/sites/default/files/20210219_mp-recht_luecker_hpcosmos_lifetime_of_a_medical_device_lr.pdf)

## 16 Disposal

Dispose the device according to European directive 2012/19/EU and the corresponding local disposal law.

Dispose the lubrication material according to the corresponding local disposal law.

Contact [service@hpcosmos.com](mailto:service@hpcosmos.com) to receive further information or an offer regarding correct disposal by the manufacturer.

The deletion of personal data on the old devices must be carried out by the end user on their own responsibility.



## 17 Annex I

### 17.1 Installation

This device must only be unpacked, transported, installed, commissioned, instructed, maintained and repaired by h/p/cosmos service personnel (see maintenance).

If the packaging has been damaged, please contact [service@hpcosmos.com](mailto:service@hpcosmos.com) immediately.

Make sure no objects, sand, stones, liquids, towels, jewellery, cell phones, containers with liquid etc. can fall into the device or onto the running surface or underneath the running belt.

It is the customer's responsibility to ensure the following conditions before the installation:

- There must be a separate power circuit for the device (dedicated line and fuse).
- There must be a separate wall socket for the device (electrically interlocked with circuit breaker 16A, type C).
- The wall socket has to be marked with the serial number of the device to ensure it is connected to this socket only.
- Use ground wire plugs with tested ground wires only.
- The intended location must provide a suitable potential equalization condition (e.g. PE-bolt).
- If in compliance with local / national standards, use type B RCDs (residual current operated protective device).
- Type B RCDs are used in cases where the application may create smooth DC residual current or contain frequencies higher than 50 Hz. For example, three- phase devices containing a motor controlled by a three-phase variable speed drive (frequency inverter drive)
- For some type B RCDs (measuring also DC direct current) an additional leakage current limiter may have to be installed.
- The intended location must provide the requirements for electrical installation acc. to "technical data".
- The intended location must maintain the local requirements for electrical installation.
- The wall socket has to be accessible at all times for maintenance and emergency disconnection situations.
- The intended location must meet the environmental conditions (see "technical data").
- The intended location must be capable of bearing the load of the device (see "technical data").
- The intended location must provide the safety area and free area as stated in "position of subject and operator".
- The intended location must provide a ceiling height, high enough for device + accessories (fall prevention).
- The intended location must provide a stable, levelled and non-slippery base/floor to prevent noise, bouncing or malfunction.
- A minimum of two people are required when lifting, lowering or moving the treadmill.
- Route power cord and communication cable away from moving parts and potential walking areas.

The manufacturer does not assume liability for any damage, complaints or missing parts that are not reported immediately upon delivery on the packing list/delivery note.

Disconnect power plug when device is not used for long periods.

## 17.2 Commissioning and instruction protocol

When installing the device, the h/p/cosmos service personnel instructs the intended operator according to the instructions for use, following this instruction protocol.

With the name and signature on the commissioning and instruction protocol, the customer confirm that the installation, commissioning and instruction has been performed correctly and instructed persons fully know how to operate the device safely. The instructed persons confirm they are able to instruct further operators according to this protocol.

No.	Information	Chapter	Check
1.	These instructions for use are available on request as print version at <a href="mailto:service@hpcosmos.com">service@hpcosmos.com</a> Please refer to the latest version of this document, available at: <a href="http://www.hpcosmos.com">www.hpcosmos.com</a>	-	
2.	The instructions for use are to be read in full before starting with the operation.	-	
3.	The safety information is explained and understood in detail.	Safety	
4.	The safety information must be displayed within sight of the device.	Safety	
5.	The function of all safety equipment is explained in detail.	Safety	
6.	The necessity and the use of a fall prevention system is explained in detail.	Safety	
7.	Exclude access of unsupervised children (< 14 years) onto or near any parts of the device has been explained.	Position of S+O	
8.	The residual risk of strangulation and trapping of clothes / shoes / fingers / hair or other (body) parts in the elevation system, belt re-entry-zones or other moving parts can not be excluded has been explained.	Position of S+O	
9.	The functions of the UserTerminal with keys, displays, programs, software and connectors are explained in detail.	UserTerminal	
10.	The general use is explained (incl. manual, profile, cardio and test mode).	Operation	
11.	The competences and intervals for maintenance are explained.	Maintenance	
12.	The adjustment of the running belt is explained in detail.	Maintenance	
13.	The lubrication of the device and owner's observation duties are explained in detail.	Maintenance	
14.	The accompanying documents are explained and handed over.	-	

### 17.3 Commissioning and instruction protocol, signatures

By signing this protocol, the authorized h/p/cosmos service personnel and the customer confirm the receipt and understanding of all safety information, the performed instruction and commissioning according to the instruction protocol [cos15228-03]. The customer confirms the receipt of the listed devices including all accessories and options according to the h/p/cosmos delivery note. Disregard of safety information, intended or forbidden use, as well as unauthorized maintenance or lack of maintenance and regular safety checks may lead to injury or even death and can damage the device. Furthermore, this will result in loss of liability and warranty. Please fill out the instruction protocol and send it back to h/p/cosmos by fax (+49 18 05 16 76 69), email ([sales@hpcosmos.com](mailto:sales@hpcosmos.com)) or mail.

h/p/cosmos sports & medical gmbh  
 Am Sportplatz 8  
 DE-83365 Nussdorf-Traunstein  
 Germany

customer's stamp / address:

h/p/cosmos device, model name	device serial number

instructor	name in clear block letters	h/p/cosmos dealer / technician	date and signature

instructed persons (customer, operator, etc.)	name in clear block letters	h/p/cosmos dealer / technician	date and signature

## 18.2 Graded test

Description	Illustration
-------------	--------------

(e.g. for performance diagnostics based on lactate measurement)  
 Refer to "test mode" for safety information and adjustment.

Parameter	Default value
Starting speed	8.0 km/h
Increment	2.0 km/h
Acceleration level	4
Step length	3:00 min
Break time	0:30 min

Each parameter is adjustable.

STOP must be activated manually by the medical doctor.

Skip remaining break time:

- Press "start" once            restart after countdown
- Press "start" twice           restart immediately

Prolong break:

- Press "-" within break        "pause" is indicated
- Press "start" to continue

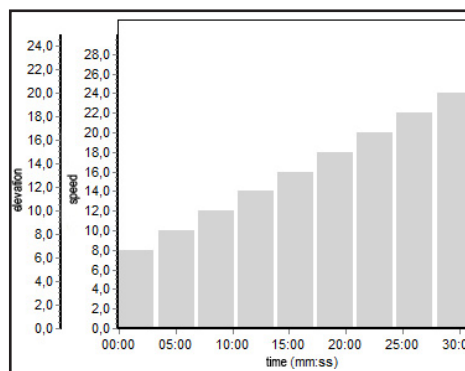

## 18.3 Conconi test

Description	Illustration
-------------	--------------

(e.g. for performance diagnostics based on heart rate measurement)  
 Refer to "test mode" for safety information and adjustment.

Endurance test (max. heart rate test)

Standard load profile:

- Starting speed: 8.0 km/h, must be changed according to the condition of the subject
- Circuit (lap length): 200 m (can be changed)
- Increment: 0.5 km/h (can be changed)

STOP must be activated manually by the medical doctor

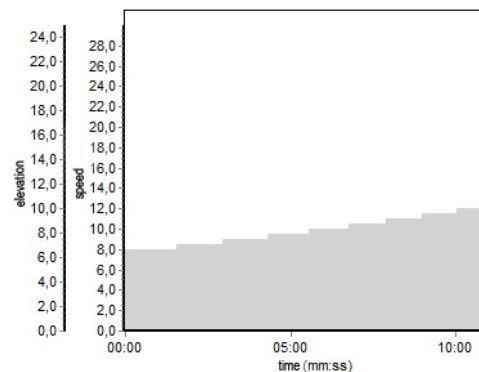

## 18.4 Bruce protocol

Description	Illustration
-------------	--------------

e.g. for ECG stress test  
Refer to "test mode" for safety information and adjustment.

Step	Duration (min)	Speed (km/h)	Elevation (%)
1	3:00	2.7	10
2		4.0	12
3		5.4	14
4		6.7	16
5		8.0	18
6		8.8	20
7		9.6	22

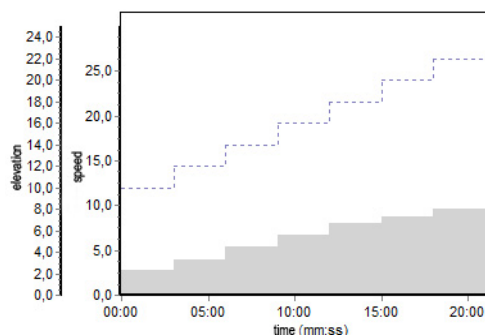

## 18.5 Naughton protocol

Description	Illustration
-------------	--------------

e.g. for ECG stress test  
Regard chapter "test mode" for safety information and adjustment.

Step	Duration (min)	Speed (km/h)	Elevation (%)
1	3:00	3.0	0.0
2			3.5
3			7.0
4			10.5
5			14.0
6			17.5

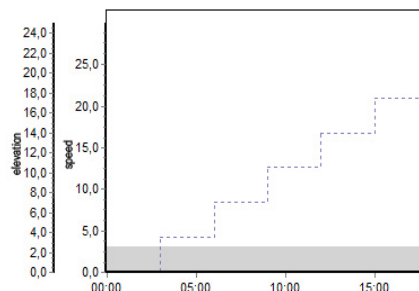

## 18.6 Balke protocol

Description	Illustration
-------------	--------------

e.g. for ECG stress test  
Refer to "test mode" for safety information and adjustment.

Step	Duration (min)	Speed (km/h)	Elevation (%)
1	2:00	5.0	2.5
2			5.0
3			7.5
4			10.0
5			12.5
6			15.0
7			17.5
8			20.0
9			22.5
10			25.0

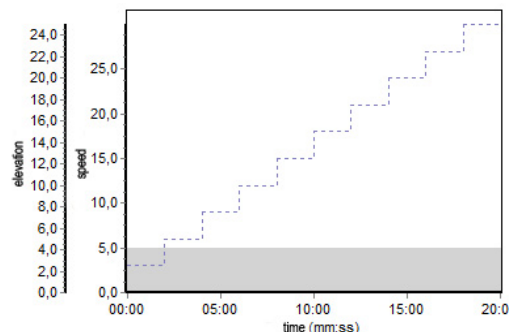

## 18.7 Cooper protocol

Description	Illustration
-------------	--------------

e.g. for ECG stress test  
 Refer to "test mode" for safety information and adjustment.

- Start at 5.3 km/h and 0% elevation
- After 1 minute elevation increases to 2 %
- After another minute, the elevation is increased by 1% every minute
- When elevation is 25 % elevation stays constant and the speed is increased by 0.32 km/h every minute

STOP must be activated manually by the medical doctor.

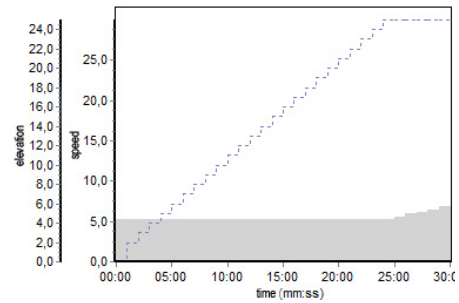

## 18.8 Ellestad A protocol

Description	Illustration
-------------	--------------

e.g. for ECG stress test  
 Regard chapter "test mode" for safety information and adjustment.

Step	Duration (min)	Speed (km/h)	Elevation (%)
1	3:00	2.7	10.0
2		4.8	
3		6.4	
4		8.0	

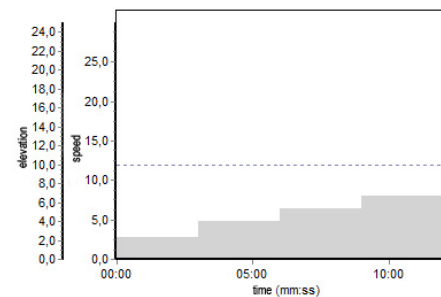

## 18.9 Ellestad B protocol

Description	Illustration
-------------	--------------

e.g. for ECG stress test  
 Refer to "test mode" for safety information and adjustment.

Step	Duration (min)	Speed (km/h)	Elevation (%)
1	3:00	2.7	10.0
2		4.8	10.0
3		6.4	10.0
4		8.0	10.0
5		8.0	15.0
6		9.6	15.0

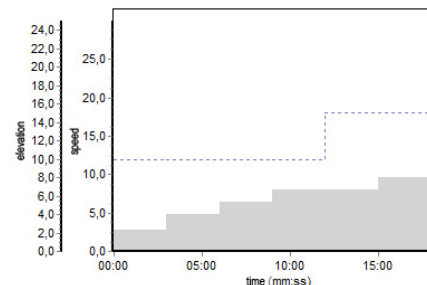

## 18.10 Ramp profile

Description	Illustration
<p>(not available for every model) Refer to "test mode" for safety information and adjustment.</p> <p>Ramp profile with 2 parameters:</p> <ul style="list-style-type: none"> <li>Target speed standard: 10.0 km/h; adjustable from 0 to maximum speed of the treadmill.</li> <li>Time for reaching target speed in seconds: standard: 10 seconds; adjustable from 0 to 99 seconds</li> </ul>	

## 18.11 Gardner test protocol

Description	Illustration																																																																						
<p>For application in angiology Refer to "test mode" for safety information and adjustment. Pre-test phase: Subject stands on the footboards, not on the belt.</p> <table border="1"> <thead> <tr> <th>Step</th> <th>Duration (min:sec)</th> <th>Speed (km/h)</th> <th>Elevation (%)</th> <th>Total time (min:sec)</th> </tr> </thead> <tbody> <tr> <td>0</td> <td>until START is pressed</td> <td>3.2</td> <td>0</td> <td>until START is pressed</td> </tr> </tbody> </table> <p>Test phase: Subject steps onto the running belt.</p> <table border="1"> <thead> <tr> <th>Step</th> <th>Duration (min:sec)</th> <th>Speed (km/h)</th> <th>Elevation (%)</th> <th>Total time (min:sec)</th> </tr> </thead> <tbody> <tr><td>1</td><td>02:00</td><td>3.2</td><td>0</td><td>2:00</td></tr> <tr><td>2</td><td>02:00</td><td>3.2</td><td>2</td><td>4:00</td></tr> <tr><td>3</td><td>02:00</td><td>3.2</td><td>4</td><td>6:00</td></tr> <tr><td>4</td><td>02:00</td><td>3.2</td><td>6</td><td>8:00</td></tr> <tr><td>5</td><td>02:00</td><td>3.2</td><td>8</td><td>10:00</td></tr> <tr><td>6</td><td>02:00</td><td>3.2</td><td>10</td><td>12:00</td></tr> <tr><td>7</td><td>02:00</td><td>3.2</td><td>12</td><td>14:00</td></tr> <tr><td>8</td><td>02:00</td><td>3.2</td><td>14</td><td>16:00</td></tr> <tr><td>9</td><td>02:00</td><td>3.2</td><td>16</td><td>18:00</td></tr> <tr><td>10</td><td>02:00</td><td>3.2</td><td>18</td><td>20:00</td></tr> <tr><td>11</td><td>30:00</td><td>3.2</td><td>18</td><td>50:00</td></tr> </tbody> </table>	Step	Duration (min:sec)	Speed (km/h)	Elevation (%)	Total time (min:sec)	0	until START is pressed	3.2	0	until START is pressed	Step	Duration (min:sec)	Speed (km/h)	Elevation (%)	Total time (min:sec)	1	02:00	3.2	0	2:00	2	02:00	3.2	2	4:00	3	02:00	3.2	4	6:00	4	02:00	3.2	6	8:00	5	02:00	3.2	8	10:00	6	02:00	3.2	10	12:00	7	02:00	3.2	12	14:00	8	02:00	3.2	14	16:00	9	02:00	3.2	16	18:00	10	02:00	3.2	18	20:00	11	30:00	3.2	18	50:00	<p>The Gardner test protocol serves to evaluate the maximum walking distance of peripheral arterial disease subjects with intermittent claudication.</p> <p>The test is to be performed under constant supervision of a medical doctor.</p> <p>The subject first stands on the side footboards of the running machine and not on the belt. Start test profile 11 and the belt speeds up to 3.2 km/h. As the subject steps onto the running belt, the doctor presses the START key again. By pressing the START key the second time, the displays will be reset to zero.</p>
Step	Duration (min:sec)	Speed (km/h)	Elevation (%)	Total time (min:sec)																																																																			
0	until START is pressed	3.2	0	until START is pressed																																																																			
Step	Duration (min:sec)	Speed (km/h)	Elevation (%)	Total time (min:sec)																																																																			
1	02:00	3.2	0	2:00																																																																			
2	02:00	3.2	2	4:00																																																																			
3	02:00	3.2	4	6:00																																																																			
4	02:00	3.2	6	8:00																																																																			
5	02:00	3.2	8	10:00																																																																			
6	02:00	3.2	10	12:00																																																																			
7	02:00	3.2	12	14:00																																																																			
8	02:00	3.2	14	16:00																																																																			
9	02:00	3.2	16	18:00																																																																			
10	02:00	3.2	18	20:00																																																																			
11	30:00	3.2	18	50:00																																																																			



## 18.12 Fitkids test





Description	Illustration
-------------	--------------

Fitkids increases speed and elevation. The target is to measure the duration a proband can achieve. Test is only available hile running direction is forward.



## 19 Annex III (Accessories)

### Emergency stop retrofitting [cos15933, cos100548, cos15294]

Title	Description			
Short description	Additional emergency stop buttons			
	cos15933	Emergency stop button with magnet holder 5m		
	cos100548	Emergency stop button with magnet holder 10m		
	cos15294	Emergency stop ext. without attachment 5m		
	cos15294 L10m	Emergency stop ext. without attachment 10m		
	cos15294 L15m	Emergency stop ext. without attachment 15m		
Illustration				
	with magnet holder		without attachment	
Application	Operation	Result	Release	Restart
	 <p>Push button</p>	<p>Running belt stops with predefined deceleration</p> <p>Movement of elevation system stops</p> <p>UserTerminal displays "pull stop"</p> <p>Mains connection and interface communication not interrupted</p>	 <p>Release button</p>	Restart application
Additional safety information	N/A			
Technical data	N/A			
Additional accessories	N/A			
Installation	By operator			
Further information	<a href="https://www.hpcosmos.com/en/products/individual-products/emergency-stop-button-magnet-holder-5-m-spiral-cable">https://www.hpcosmos.com/en/products/individual-products/emergency-stop-button-magnet-holder-5-m-spiral-cable</a>			



## Arm support, optional stop button [cos10107, cos10108]

Title	Description
-------	-------------

Short description Additional emergency stop, integrated into arm support

Illustration



Application	Operation	Result	Release	Restart
	 <p>Push button</p>	<p>Running belt stops with predefined deceleration</p> <p>Movement of elevation system stops</p> <p>UserTerminal displays "pull stop"</p> <p>Mains connection and interface communication not interrupted</p>	 <p>Release button</p>	 <p>Restart application</p>
Additional safety information	N/A			
Technical data	N/A			
Additional accessories	N/A			
Installation	By h/p/cosmos service personnel, only			
Further information	<a href="https://www.hpcosmos.com/en/products/individual-products/additional-stop-button-right">https://www.hpcosmos.com/en/products/individual-products/additional-stop-button-right</a>			

## Elevation 0% to +25% [cos102927]

Title	Description
Short description	Extends elevation to 25% (14.0°)
Illustration	N/A
Application	N/A
Additional safety information	N/A
Technical data	Max. elevation: 25% 14.0°
Additional accessories	N/A
Installation	By h/p/cosmos service personnel, only
Further information	N/A

## Special speed 0 to 22 km/h, 150/50 LC [cos103326]

Title	Description
Short description	Extends speed to 22.0 km/h (6.1 m/s, 13.7 mph)
Illustration	N/A
Application	N/A
Additional safety information	N/A
Technical data	Max. speed: 22.0 km/h 6.1 m/s 13.7 mph
Additional accessories	N/A
Installation	By h/p/cosmos service personnel, only
Further information	N/A

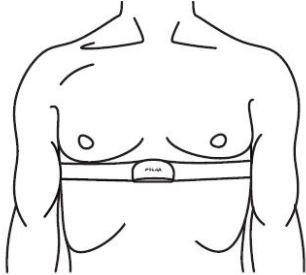

## Heart rate measurement POLAR non-coded [cos102818]

Title	Description												
Short description	Heart rate measurement, non-coded												
Illustration													
Application	<p>Apply chest belt as shown:</p> 												
Additional safety information and exercise test stop criteria	<ul style="list-style-type: none"> <li>■ <b>WARNING!</b> Heart rate monitoring systems may be inaccurate.</li> <li>■ Incorrect or over exercising may result in serious injury or death.</li> <li>■ If you feel faint or dizzy stop exercising immediately and consult a medical doctor.</li> <li>■ Further exercise test stop criteria see guidelines for various treadmill exercise and treadmill tests.</li> </ul>												
Technical data	<p>Transmission radius: approx. 1m            Further data see accompanying POLAR documents or <a href="http://www.polar.com">www.polar.com</a>.</p> <p><u>Troubleshooting:</u>            In case the heart rate is not displayed:</p> <ul style="list-style-type: none"> <li>- Chest belt might be applied incorrectly (see application above)</li> <li>- Other chest belt than POLAR T31 or T34 is used (see print)</li> </ul> <p>If the heart rate is not displayed or displayed incorrectly:            There might be interferences with</p> <ul style="list-style-type: none"> <li>- Screens, computers, printers, mobile phones and any radio engineering systems</li> <li>- Electric devices, electric motors, transformers</li> <li>- High-voltage transmission lines, also from trains</li> <li>- Strong fluorescent tubes nearby</li> <li>- Central heating radiators</li> <li>- Other electric devices</li> </ul> <p>In order to prevent interference of the running machine, place the device at some distance away from such sources of interference. Do not rely on the indicated values if you suspect interference.            Please refer to the instructions provided by the manufacturer, POLAR.</p>												
Additional accessories	<table border="0"> <tr> <td>cos10905</td> <td>POLAR chest belt XS</td> </tr> <tr> <td>cos10906</td> <td>POLAR chest belt S</td> </tr> <tr> <td>cos10165</td> <td>POLAR chest belt M</td> </tr> <tr> <td>cos10907</td> <td>POLAR chest belt L</td> </tr> <tr> <td>cos10902</td> <td>POLAR transmitter set T31</td> </tr> <tr> <td>cos15178</td> <td>POLAR transmitter set T34 (extended range)</td> </tr> </table>	cos10905	POLAR chest belt XS	cos10906	POLAR chest belt S	cos10165	POLAR chest belt M	cos10907	POLAR chest belt L	cos10902	POLAR transmitter set T31	cos15178	POLAR transmitter set T34 (extended range)
cos10905	POLAR chest belt XS												
cos10906	POLAR chest belt S												
cos10165	POLAR chest belt M												
cos10907	POLAR chest belt L												
cos10902	POLAR transmitter set T31												
cos15178	POLAR transmitter set T34 (extended range)												
Installation	By h/p/cosmos service personnel, only												
Further information	N/A												

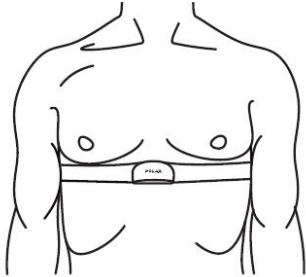
# Heart rate measurement POLAR H10 [cos101787-01]



Title	Description
Short description	Heart rate measurement coded
Illustration	
Application	Apply chest belt as shown: 
Additional safety information and exercise test stop criteria	<ul style="list-style-type: none"><li>■ <b>WARNING!</b> Heart rate monitoring systems may be inaccurate.</li><li>■ Incorrect or over exercising may result in serious injury or death.</li><li>■ If you feel faint or dizzy stop exercising immediately and consult a medical doctor.</li><li>■ Further exercise test stop criteria see guidelines for various treadmill exercise and treadmill tests.</li></ul>
Trouble-shooting	<ul style="list-style-type: none"><li>■ In case the heart rate is not displayed or not displayed correctly:</li><li>■ The heart rate transmitter might not yet be paired (click on heart symbol)</li><li>■ The heart rate transmitter might not be compatible (see print on transmitter)</li><li>■ The heart rate transmitter might be applied incorrectly (see above) or skin is too dry</li><li>■ The battery of the heart rate transmitter might be low</li><li>■ There might be interferences with electric devices such as Screens, computers, printers, mobile phones and any radio engineering systems, electric motors, transformers, high-voltage transmission lines, also from trains, strong fluorescent tubes, central heating radiators, etc.</li></ul> <p>In order to prevent interference avoid the vicinity of such devices.</p> <p>Do not rely on the indicated values if you suspect interference.</p> <p>Please refer to the instructions provided by the manufacturer, POLAR.</p> <p><a href="http://www.polar.com">www.polar.com</a>.</p>
Additional accessories	cos100420b POLAR H10 transmitter
Installation	By operator
Further information	<a href="https://www.hpcosmos.com/en/polar-heart-rate-sensor-h10">https://www.hpcosmos.com/en/polar-heart-rate-sensor-h10</a>

# Heart rate measurement POLAR OH1 [cos101787\_OH1]

Title	Description
Short description	Polar OH1 is a compact optical heart rate sensor (coded with Bluetooth transmission) that measures heart rate from your arm or temple.
Illustration	
Application	Apply sensor and belt as shown: 
Additional safety information and exercise test stop criteria	<ul style="list-style-type: none"><li>■ <b>WARNING!</b> Heart rate monitoring systems may be inaccurate.</li><li>■ Incorrect or over exercising may result in serious injury or death.</li><li>■ If you feel faint or dizzy stop exercising immediately and consult a medical doctor.</li><li>■ Further exercise test stop criteria see guidelines for various treadmill exercise and treadmill tests.</li></ul>
Trouble-shooting	<ul style="list-style-type: none"><li>■ In case the heart rate is not displayed or not displayed correctly:</li><li>■ The heart rate transmitter might not yet be paired (click on heart symbol)</li><li>■ The heart rate transmitter might not be compatible (see print on transmitter)</li><li>■ The heart rate transmitter might be applied incorrectly (see above) or skin is too dry</li><li>■ The battery of the heart rate transmitter might be low</li><li>■ There might be interferences with electric devices such as Screens, computers, printers, mobile phones and any radio engineering systems, electric motors, transformers, high-voltage transmission lines, also from trains, strong fluorescent tubes, central heating radiators, etc.</li></ul> <p>In order to prevent interference avoid the vicinity of such devices.</p> <p>Do not rely on the indicated values if you suspect interference.</p> <p>Please refer to the instructions provided by the manufacturer, POLAR.</p> <p><a href="http://www.polar.com">www.polar.com</a>.</p>
Additional accessories	N/A
Installation	By operator
Further information	<a href="#">N/A</a>



## Arm support, adjustable [cos12013]

Title	Description	
Short description	The h/p/cosmos arm supports are a simple solution for unweighting of the subject. Height and width adjustability offers a wide field of application.	
Illustration		
Application	<p>Adjust the arm support by pulling the locking element and turning the segments.</p> <p>Hold free segments with other hand.</p> <p>Scales on each joint allow reproducibility.</p>	
Additional safety information	<ul style="list-style-type: none"> <li>■ Do not adjust under load.</li> <li>■ Use caution at squeeze and shear points.</li> <li>■ Make sure the hand grips are in upright position during use.</li> <li>■ Do not use for running.</li> <li>■ Position arm supports outside of training area when running.</li> <li>■ Do not use on bare skin.</li> <li>■ Do not leave the arm support in a position that projects into running area</li> <li>■ Before loading, make sure the adjustment elements are correctly locked.</li> <li>■ Do not use the arm supports with reverse belt rotation.</li> </ul>	
Technical data	<p>Adjustability:</p> <p>Measurements:</p> <p>Weight:</p> <p>Max. subject weight:</p> <p>Max. subject weight of treadmill is reduced when combined with arm support.</p>	<p>Height and width via 3 joints</p> <p>48 x 42.5 x 26 cm each (packed)</p> <p>10.7 kg each</p> <p>140 kg</p>
Additional accessories	<p>cos100680</p> <p>cos14135</p> <p>cos10107</p> <p>cos10108</p>	<p>additional keyboard for arm support</p> <p>keyboard holder for arm support</p> <p>additional stop button in right arm support</p> <p>additional stop button in left arm support</p>
Installation	By h/p/cosmos service personnel, only	
Further information	<a href="https://www.hpcosmos.com/en/products/individual-products/adjustable-arm-supports-scale-0deg-handrail-shape">https://www.hpcosmos.com/en/products/individual-products/adjustable-arm-supports-scale-0deg-handrail-shape</a>	

## robowalk expander [cos30022, cos30023]

Title	Description												
Short description	The h/p/cosmos robowalk expander supports gait training. Expander ropes, attached to the limbs, support or load the subject.												
Illustration													
Application	<p>The h/p/cosmos robowalk® expander is attached to the h/p/cosmos treadmill. In total it consists of 8 expander cables, 4 in the front, and 4 in the rear. The expander cables are attached to the patient via leg cuffs.</p> <p>With the h/p/cosmos robowalk® expander you can either support or load the patient.</p>												
Additional safety information	<p>Do not use the cuffs on bare skin.</p> <p>Take special care for your fingers around the cable rolls and adjustment bolts to prevent squeezing.</p> <p>Mandatory fall prevention device for any applications with robowalk expander. A safety lanyard (pull cord device with magnet clip, etc.) is not considered to be sufficient to prevent from falling!</p>												
Technical data robowalk front [cos30022]	<p>Height: approx. 110 cm (depending on treadmill)</p> <p>Weight: approx. 15 kg (depending on treadmill)</p> <p>Max. pulling force: 50 N per rope</p>												
Technical data robowalk back [cos30023]	<p>Height: approx. 80 cm (depending on treadmill)</p> <p>Weight: approx. 25 kg (depending on treadmill)</p> <p>Max. pulling force: 50 N per rope</p>												
Additional accessories	<table border="0"> <tr> <td>cos101051-XS</td> <td>leg cuff XS shank</td> <td>(for circumference 14 ... 27 cm)</td> </tr> <tr> <td>cos101050-S</td> <td>leg cuff S thigh</td> <td>(for circumference 25 ... 39 cm)</td> </tr> <tr> <td>cos101050-M</td> <td>leg cuff M</td> <td>(for circumference 36 ... 51 cm)</td> </tr> <tr> <td>cos101050-L</td> <td>leg cuff L</td> <td>(for circumference 49 ... 75 cm)</td> </tr> </table>	cos101051-XS	leg cuff XS shank	(for circumference 14 ... 27 cm)	cos101050-S	leg cuff S thigh	(for circumference 25 ... 39 cm)	cos101050-M	leg cuff M	(for circumference 36 ... 51 cm)	cos101050-L	leg cuff L	(for circumference 49 ... 75 cm)
cos101051-XS	leg cuff XS shank	(for circumference 14 ... 27 cm)											
cos101050-S	leg cuff S thigh	(for circumference 25 ... 39 cm)											
cos101050-M	leg cuff M	(for circumference 36 ... 51 cm)											
cos101050-L	leg cuff L	(for circumference 49 ... 75 cm)											
Installation	By h/p/cosmos service personnel, only												
Further information	<a href="https://www.hpcosmos.com/en/products/individual-products/robowalk-expander-f-15050">https://www.hpcosmos.com/en/products/individual-products/robowalk-expander-f-15050</a>												

## OptoGait, OptoJump [cos102065, cos102054]

Title	Description
Short description	Optical measurement of gait parameters

Illustration

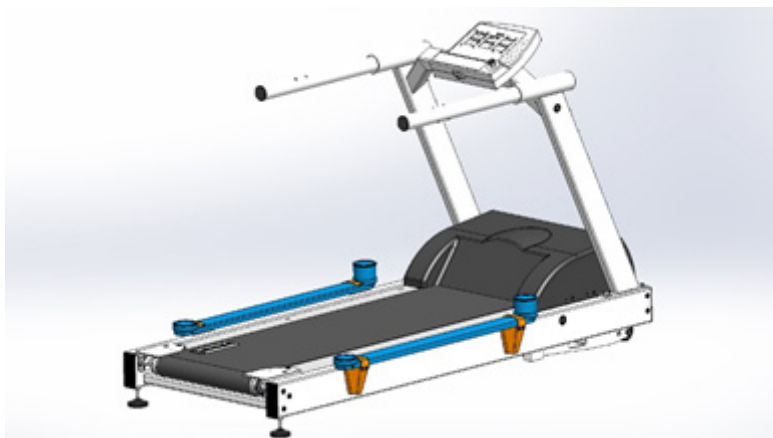

Application	<ul style="list-style-type: none"> <li>■ Clip Optogait / Optojump into optofix profiles.</li> <li>■ The fastening profiles can be fixed without tools, only by magnetic force.</li> <li>■ The option is independent of the frame height.</li> <li>■ Analysis via external PC (software included).</li> </ul>
Additional safety information	Do not step on the fixed bars or fastening profiles!
Technical data	Length: 120 cm Width: 10 cm Height: 15 cm
Additional accessories	cos103386 optofix cos100699_LED speedcontrol software
Installation	By operator
Further information	<a href="https://www.hpcosmos.com/en/products/medicine-therapy/motion-analysis-optogait">https://www.hpcosmos.com/en/products/medicine-therapy/motion-analysis-optogait</a>

# optofix [cos103386]

Title	Description
-------	-------------

Short description      Option for fixing optogait / optojump on treadmill

Illustration



Application

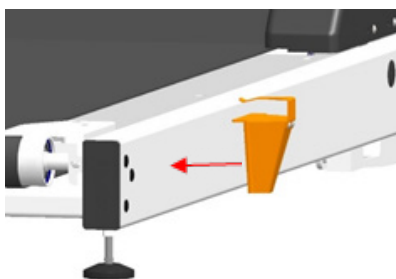

Attach optofix to treadmill (magnet)

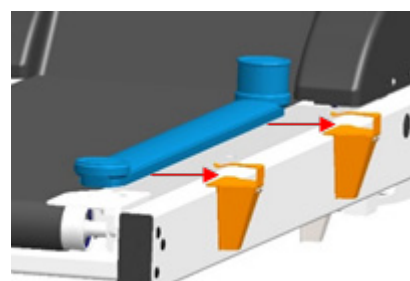

Attach optogait/optojump to optofix (clamp)

This option makes it easy to fix optogait / optojump bars on the treadmill. The fastening profiles can be fixed without tools, only by magnetic force. The option is independent of the frame height. Do not step on optofix™!



Additional safety information

Do not step on the fixed bars or fastening profiles. In case there is no optogait / optojump, the optofix has to be removed. not usable with mounted footboard.

Technical data

Length:      12 cm  
 Width:      8.6 cm  
 Height:      14.9 cm

Additional accessories

cos102065      optogait kit 1m  
 cos102054      optojump kit 1m

Installation

By operator

Further information

<https://www.hpcosmos.com/en/optofix>

## Satellite PC med [cos14970-03]

Title	Description
Short description	PC unit certified as medical electrical system with h/p/cosmos treadmills
Illustration	
Application	External treadmill control as well as data analysis. Use of software such as paracontrol, gaitway 3D, zebris, noraxon, etc.
Additional safety information	Do not step on the fixed bars or fastening profiles!
Technical data	measurements: 150 x 60 x 100 cm mass: 80 kg
Additional accessories	N/A
Installation	By h/p/cosmos service personnel, only Regard wiring diagram, provided on following website.
Further information	<a href="https://www.hpcosmos.com/en/products/supplies-options/hpcosmos-satellite-pc-med">https://www.hpcosmos.com/en/products/supplies-options/hpcosmos-satellite-pc-med</a>



# Handrail, adjustable [cos102010], [cos102550], [cos102551]

Title	Description
-------	-------------

Short description handrails adjustable in height and width at both sides

Illustration

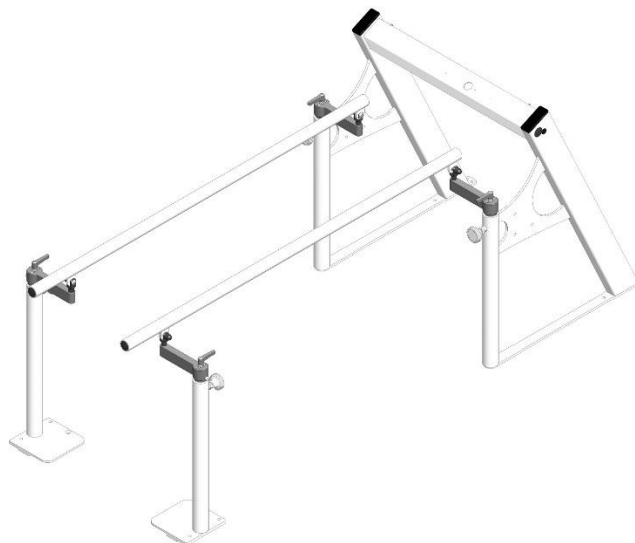

Application



Height adjustment:  
Pull locking knob and move handrail to desired position. Hold free segments with other hand.

Width adjustment:  
Loosen lever, turn swivel arm, tighten lever.

Additional safety information

- Do not adjust under load.
- Be careful with squeeze and shear points.
- Pay attention to the right position of the handrails.
- Before loading, make sure the adjustment elements are correctly locked.

Technical data

	150/50	170-190/65
adjustability:	height: 55 – 120 cm	height: 75 – 120 cm
	width: 38 – 104 cm	width: 62 – 128 cm
handrail tube length:	150 cm	170/190 cm
tube diameter:	4 cm	4 cm
weight:	69 kg	71 kg
material:	steel tube, powder coated	steel tube, powder coated

Installation

By h/p/cosmos service personnel, only

Further information

<https://www.hpcosmos.com/en/products/supplies-options/handrails-both-sides-adjustable-17065>  
<https://www.hpcosmos.com/en/products/supplies-options/handrails-both-sides-adjustable-19065>

## Handrail, long 1358mm [cos102918]

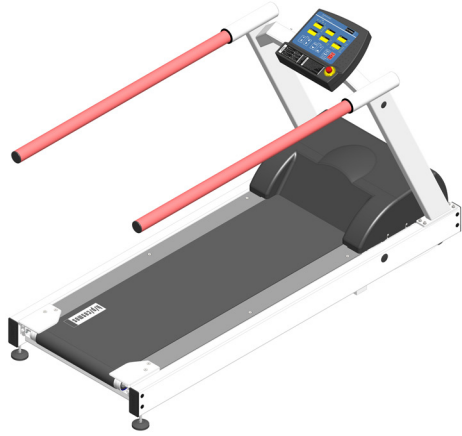
Title	Description
Short description	Long handrail for additional safety
Illustration	
Application	Subject has to hold both handrails for stability when entering the treadmill. Subject may hold handrails for balance control. Holding handrails during use affects exercise results.
Additional safety information	N/A
Technical data	Length: 135.8 cm Diameter: 4 cm Weight: 9.5 kg (4.0 kg additional weight)
Additional accessories	N/A
Installation	By h/p/cosmos service personnel, only
Further information	<a href="https://www.hpcosmos.com/en/products/supplies-options/handrail-long-1-pillar-15050-lc">https://www.hpcosmos.com/en/products/supplies-options/handrail-long-1-pillar-15050-lc</a>



## Handrail, pediatric [cos102400]

Title	Description
Short description	Additional handrail for small subjects
Illustration	 <p>The illustration shows a red metal handrail structure with two horizontal bars. A black control console with a digital display and several buttons is mounted on the right side of the handrail. The handrail is shown in a perspective view, attached to a grey base.</p>
Application	<p>Subject may hold handrails for balance control.            Holding handrails during use affects exercise results.</p>
Additional safety information	N/A
Technical data	<p>Length: 91 cm            Width: 85.5 cm            Height: 54.3 cm            Max. subject weight: 50 kg            Max. subject weight of treadmill is reduced when combined with arm support.</p>
Additional accessories	N/A
Installation	By h/p/cosmos service personnel, only
Further information	<a href="https://www.hpcosmos.com/en/products/supplies-options/children-handrail-treadmill15050-lc">https://www.hpcosmos.com/en/products/supplies-options/children-handrail-treadmill15050-lc</a>

## Handrail, short (speed) left / right [cos14763-01, cos102803]

Title	Description
Short description	extra short handrail for speed applications
Illustration	
Application	Subject may hold handrails for balance control. Holding handrails during use affects exercise results.
Additional safety information	N/A
Technical data	Lenght: 132 cm Diameter: 6 cm Height: 98.5 cm Weight: 12 kg (each)
Additional accessories	N/A
Installation	By h/p/cosmos service personnel, only
Further information	<a href="https://www.hpcosmos.com/en/products/supplies-options/handrail-left-shortened-speed-xx65">https://www.hpcosmos.com/en/products/supplies-options/handrail-left-shortened-speed-xx65</a>

## Handrail very short [cos103322]

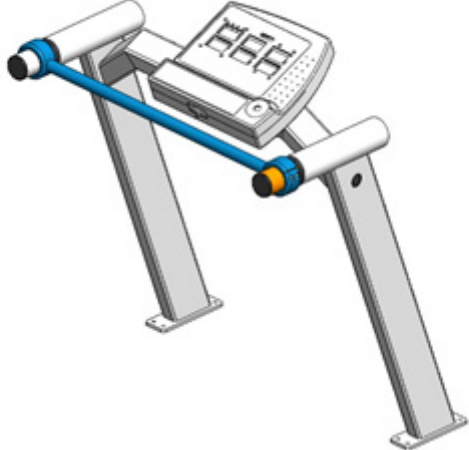
Title	Description
Short description	Very short handrail for better lateral sight
Illustration	
Application	Due to its short length, the handrails enable a good lateral sight on the subject. Thereof the application is for example in the area of motion analyses.
Additional safety information	Use of crossbar [cos102426] is obligatory!
Technical data	Length: 70 cm Diameter: 4 cm Weight: 1.3 kg
Technical data	Length: 40 cm remaining grip length: 18 cm diameter: 6 cm weight: 1.3 kg weight: steel tube, powder coated
Installation	By h/p/cosmos service personnel, only
Further information	N/A

## Foot rails wide [cos103928]

Title	Description
Short description	Set of extra wide foot rails for treadmill 150/50
Illustration	 <p>The illustration shows a treadmill with a black running deck and silver frame. Two long, white, cylindrical foot rails are attached to the front of the treadmill, extending forward. A control console with a digital display is mounted on the front of the treadmill. The brand name 'h/p/cosmos' is visible on the front of the treadmill.</p>
Application	Neurological therapy Performance diagnostics
Additional safety information	Certain applications might require a fall prevention (see "safety")
Technical data	Length: 70 cm Diameter: 4 cm Weight: 1.3 kg
Technical data	Compatible devices: treadmill 150/50 (from 2020) Dimensions: 1490 x 215 mm (each) Weight: 6,5 kg (each) Treadmill width: 99 cm material: powder coated aluminum, non-slip tape
Installation	By h/p/cosmos service personnel, only
Further information	N/A

# Reverse treadmill belt rotation [cos103330], [cos00098100045-02], [cos10181-03]

Title	Description
Short description	Reverse belt rotation for downhill running / walking
Illustration	
Application	<p>Aktivate reverse belt rotation and start device without subject.</p> <p>Observe running belt position and adjust if due.</p> <p>Stop operation and guide subject onto device.</p> <p>Explain and start operation.</p> <p>Repeat procedure for switching to forward direction.</p>
Additional safety information	<ul style="list-style-type: none"> <li>■ Do not use without supervisory staff.</li> <li>■ Do not switch during motion.</li> <li>■ Max. speed for reverse belt rotation is reduced by default</li> </ul>
Technical data	<p>speed range: 0 ... 5.0 km/h (3.1 mph) in reverse mode no limitation in regular mode speed limit for reverse mode can be undone in case a fall prevention is used and in case there is no handrail crossbar or UserTerminal behind the subject.</p> <p>Modification of basic device: standard belt is replaced by reinforced belt with profiled surface and 5 mm thickness; belt guide rollers for running belt centering during reverse operation are added.</p>
Installation	By h/p/cosmos service personnel, only
Further information	<p><a href="https://www.hpcosmos.com/en/products/individual-products/reverse-belt-rotation-downhill-15050">https://www.hpcosmos.com/en/products/individual-products/reverse-belt-rotation-downhill-15050</a></p> <p><a href="https://www.hpcosmos.com/en/products/individual-products/reverse-belt-rotation-downhill-17065">https://www.hpcosmos.com/en/products/individual-products/reverse-belt-rotation-downhill-17065</a></p>

## Crossbar front rail [cos102426]

Title	Description
Short description	Crossbar for additional balance control
Illustration	
Application	<p>Subject may hold crossbar front rail for balance control</p> <p>Holding handrails during use affects exercise results.</p>
Additional safety information	<ul style="list-style-type: none"> <li>■ It is not allowed to run with the back to the crossbar or to the UserTerminal to prevent from collision.</li> <li>■ The handrail crossbar should be dismantled if a safety arch with chest belt system is installed and used. Dismounting of the handrail crossbar allows more freedom of motion and is beneficial for applications where holding a front handrail crossbar is not part of the application.</li> </ul>
Technical data	<p>Length: 70 cm</p> <p>Diameter: 4 cm</p> <p>Weight: 1.3 kg</p>
Technical data	N/A
Installation	By h/p/cosmos service personnel, only
Further information	<a href="https://www.hpcosmos.com/en/crossbar-handrail-pluto-15050-lc">https://www.hpcosmos.com/en/crossbar-handrail-pluto-15050-lc</a>

# Safety arch retrofit / replacement kit h=220cm

(cos14424-01; cos14424-01ret; cos14425-01; cos14425-01ret)

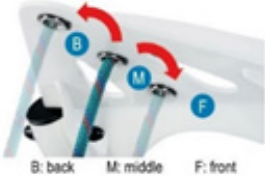
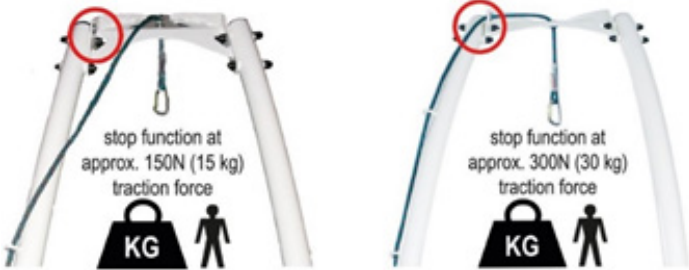

Title	Description
Short description	retrofit kit is necessary to ensure the safe use of a treadmill for test persons with a body height of 220cm
Illustration	
Application	<p>Choose position of rope outlet</p>  <p>Choose approx. triggering force</p> 
Additional safety information	Putting on the safety vest properly
Technical data	<p>Compatible devices: treadmills 150/50 &amp; 170-190/65</p> <p>Dimensions: 2600 x 1415 mm (each in assembled condition)</p> <p>Weight: 11,5 kg (only safety arch retrofit kit) 42,13 kg (complete system safety arch included retrofit kit))</p> <p>Treadmill height: cos14424-01 ; cos14424-01ret 266cm in assembled condition at 0% elevation 277cm in assembled condition at 25% elevation cos14425-01 ; cos14425-01ret 266cm in assembled condition at 0% elevation 290cm in assembled condition at 28% elevation</p> <p>material: powder coated steel</p>
Installation	Service technician

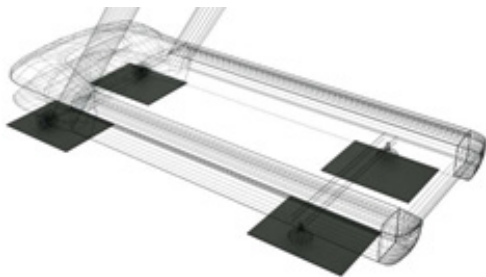
## Floor protection mat [cos103852]

Title	Description
Short description	retrofit kit is necessary to ensure the safe use of a treadmill for test persons with a body height of 220cm
Illustration	
Application	Remove foil from self-adhesive surface. Place mats at the position of the rollers. Place mats at the position of the adjustable feet (if needed).
Technical data	Measurements: 300 x 400 x 5 mm Weight: 250 g (each)
Installation	By customer

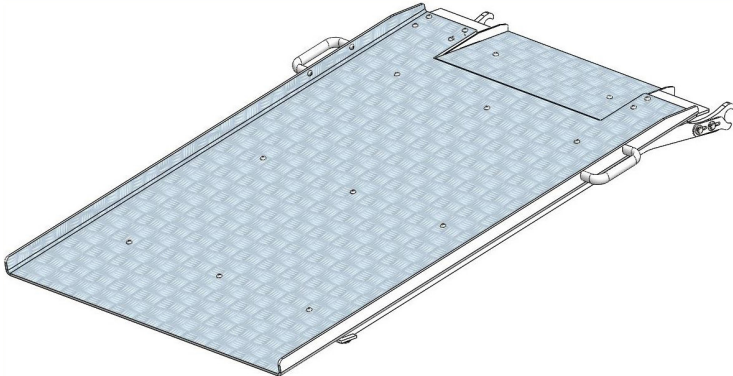

# Wheelchair ramp [cos16186-02], [cos102931], [cos14664-03]

Title	Description																
Short description	Wheelchair ramp supports entering the device with wheelchair subjects.																
Illustration																	
Application	<p>Push subject with wheelchair onto treadmill.            Connect subject to fall prevention device.            Support subject so they can stand upright.            Remove wheelchair.            Start application.</p>																
Additional safety information	<ul style="list-style-type: none"> <li>■ Do not use the device with wheels (bikes, wheelchairs, inline skates, etc.).</li> <li>■ Unmeant trapping hazards: Take off ties, scarfs or other clothes that may be trapped. Secure long hair and ribbons during maintenance and training in order to prevent being captured in trapping zones.</li> </ul> <p>The ramp must not touch the running belt.            Make sure the ramp cannot slip.            Always enter from the back, not from the side.            Do not install the ramp when running belt is in motion.</p> 																
Technical data	<table border="0"> <tr> <td></td> <td>150/50</td> <td>170-190/65</td> </tr> <tr> <td>Length:</td> <td>124 cm</td> <td>130 cm</td> </tr> <tr> <td>Width:</td> <td>82 cm</td> <td>91 cm</td> </tr> <tr> <td>Height:</td> <td>13 cm</td> <td>13 cm</td> </tr> <tr> <td>Weight:</td> <td>22 kg</td> <td>27 kg</td> </tr> </table>		150/50	170-190/65	Length:	124 cm	130 cm	Width:	82 cm	91 cm	Height:	13 cm	13 cm	Weight:	22 kg	27 kg	
	150/50	170-190/65															
Length:	124 cm	130 cm															
Width:	82 cm	91 cm															
Height:	13 cm	13 cm															
Weight:	22 kg	27 kg															
Additional accessories	N/A																
Installation	By operator																
Further information	<p><a href="https://www.hpcosmos.com/en/products/supplies-options/wheelchair-ramp-treadmill-15050">https://www.hpcosmos.com/en/products/supplies-options/wheelchair-ramp-treadmill-15050</a>  <a href="https://www.hpcosmos.com/en/wheelchair-ramp-treadmill-15050-lc">https://www.hpcosmos.com/en/wheelchair-ramp-treadmill-15050-lc</a>  <a href="https://www.hpcosmos.com/en/products/supplies-options/wheelchair-ramp-treadmill-170-19065">https://www.hpcosmos.com/en/products/supplies-options/wheelchair-ramp-treadmill-170-19065</a></p>																

## 20 Contact

For any service or sales enquiries, please have the model type and serial number of your device ready.  
For service support, we recommend using Skype with webcam.

### Service

h/p/cosmos sports & medical gmbh

Am Sportplatz 8

DE 83365 Nussdorf-Traunstein, Germany

phone +49 18 05 16 76 67 (0,14€/min from German landlines, max. 0,42€ from German mobile networks)

fax +49 18 05 16 76 69

email [service@hpcosmos.com](mailto:service@hpcosmos.com)

Skype [@hpcosmos.com](https://www.skype.com/en/contacts/voice/@hpcosmos.com) (search & select name)

### Sales

emotion fitness GmbH & Co. KG

Trippstadter Str. 68

67691 Hochspeyer

phone +49 63 05 71 49 90

fax +49 63 05 71 49 91 11

email [info@emotion-fitness.de](mailto:info@emotion-fitness.de)

### Manufacturer:

h/p/cosmos sports & medical gmbh

Am Sportplatz 8

DE 83365 Nussdorf-Traunstein, Germany

phone +49 18 05 16 76 67 (0,14€/min from German landlines, max. 0,42€ from German mobile networks)

fax +49 18 05 16 76 69

email [email@hpcosmos.com](mailto:email@hpcosmos.com)

web [www.hpcosmos.com](http://www.hpcosmos.com)

The copyright of this document, media, design, software and intellectual property is owned by h/p/cosmos sports & medical gmbh, except where explicitly stated differently.  
Warning: All rights reserved. Unauthorized copying, reproduction, hiring, lending, public performance and broadcasting prohibited.

All technical data, descriptions, equipment variants and illustrations of devices, options and accessories are non-binding, in particular do not represent warranted characteristics and can deviate from offer and delivery.

The figures could show not selected options and equipment ranges.

latest instructions  
for use / manuals:



<https://www.hpcosmos.com/en/contact-support/media-downloads/manuals>

contact h/p/cosmos:



<https://www.hpcosmos.com/en/contact-support/contact>

